



Ersatzteilkatalog

OMC

S. 742 - S. 810



Display Package

**18-5001
TUNE-UP KIT**
Replaces: 172525

—CONTAINS—

Part #	O.E. #	Description
18-5157	580290	Contact Set
18-5200	580256	Condenser



Display Package

**18-5250
TUNE-UP KIT**
Replaces: 172527

—CONTAINS—

Part #	O.E. #	Description
18-5311	380538	Contact Set
18-5345	380537	Condenser
18-5418	384735	Rotor

Delco 4 & 6 cyl.



Display Package

**18-5251
TUNE-UP KIT**
Replaces: 173619

—CONTAINS—

Part #	O.E. #	Description
18-5314	382135	Contact Set
18-5338	382136	Condenser
18-5404-1	982211	Rotor

Mallory 8 cyl. Tall Cap



**18-5252
TUNE-UP KIT**

—CONTAINS—

Part #	O.E. #	Description
18-5310	380543	Contact Set
18-5344	382125	Condenser
—	381711	Rotor

Delco 8 cyl.



**18-5256
TUNE-UP KIT**
Replaces: 172531

—CONTAINS—

Part #	O.E. #	Description
18-5314	382135	Contact Set
18-5338	382136	Condenser
18-5411	982342	Rotor

Mallory 8 cyl. Flat Cap



① 18-5258D Display Package

**18-5258
TUNE-UP KIT**
Replaces: 173690, 987925

—CONTAINS—

Part #	O.E. #	Description
18-5303	980893	Contact Set
18-5347	980894	Condenser
18-5407	980892	Rotor

Prestolite 8 cyl.



Display Package

**18-5260
TUNE-UP KIT**
Replaces: 173829, 987926

—CONTAINS—

Part #	O.E. #	Description
18-5303	980893	Contact Set
18-5347	980894	Condenser
18-5403	982880	Rotor



Flame-Thrower

**18-5266
TUNE UP KIT**
Fits: Flame Thrower Distributors 18-5481, 18-5482, 18-5483, 18-5477, 18-5478 and 18-5479



Display Package

**18-5268
TUNE-UP KIT**

—CONTAINS—

Part #	O.E. #	Description
18-5311	380538	Contact Set
18-5345	380537	Condenser
18-5418	384735	Rotor
18-5385	380541	Distributor Cap

Delco In-Line 4 - Single Point



Display Package

**18-5269
TUNE-UP KIT**

—CONTAINS—

Part #	O.E. #	Description
18-5311	380538	Contact Set
18-5345	380537	Condenser
18-5418	384735	Rotor
18-5386	980152	Distributor Cap

Delco In-Line 6 - Single Point



Display Package

**18-5270
TUNE-UP KIT**

—CONTAINS—

Part #	O.E. #	Description
18-5310	380543	Contact Set
18-5344	382125	Condenser
—	381711	Rotor
18-5384	383587	Distributor Cap

Delco V-8 - Single Point



Display Package

**18-5271
TUNE-UP KIT**

—CONTAINS—

Part #	O.E. #	Description
18-5314	382135	Contact Set
18-5338	382136	Condenser
18-5404-1	982211	Rotor
18-5376	982209	Distributor Cap

Mallory V-8 - Single Point - Top Terminal

APPLICATION BEGINS ON PAGE 750

① Items ending in "D" are Display Packaged - Regular number is Non-Display



**18-5272
TUNE-UP KIT**
—CONTAINS—

Part #	O.E. #	Description
18-5314	382135	Contact Set
18-5338	382136	Condenser
18-5411	982342	Rotor
18-5375	382133	Distributor Cap

Mallory Flat V-8 - Single Point - Side Terminal



**18-5275
TUNE-UP KIT**
—CONTAINS—

Part #	O.E. #	Description
18-5303	980893, 987136, 987894	Contact Set
18-5347	980894, 987895	Condenser
18-5403	982880	Rotor
18-5352	984401	Distributor Cap

Prestolite V-8 - Single Point - Screw Cap



**18-5276
TUNE-UP KIT**
—CONTAINS—

Part #	O.E. #	Description
18-5303	980893, 987136, 987894	Contact Set
18-5347	980894, 987895	Condenser
18-5403	982880	Rotor
18-5353	984398	Distributor Cap

Prestolite V-6 - Single Point - Screw Cap



**18-5277
TUNE-UP KIT**
—CONTAINS—

Par t#	O.E. #	Description
18-5303	980893, 987136, 987894	Contact Set
18-5347	980894, 987895	Condenser
18-5407	980892	Rotor
18-5369	982336	Distributor Cap

Prestolite V-8 - Single Point - Clip Cap



**18-5278
TUNE-UP KIT**
For: Delco EST V-6



**18-5279
TUNE-UP KIT**
For: Prestolite Electronic V-8

Part #	Description	O.E.#	Qty.
18-5352	Distributor Cap	392-9766	1
18-5403	Rotor	392-9089	1



**18-5280
TUNE-UP KIT**
For: Delco EST In-Line 4

Part #	Description	O.E.#	Qty.
18-5361	Distributor Cap	986643	1
18-5406	Rotor, Delco	986651	1



**18-5283
TUNE-UP KIT**
For: Mallory Single Point In-Line 4



**18-5157
CONTACT SET**
Replaces: 580290



**18-5303
CONTACT SET**
Replaces: 980893, 987136, 987894



**18-5310
CONTACT SET**
Replaces: 380543



**18-5311
CONTACT SET**
Replaces: 380538



**18-5314
CONTACT SET**
Replaces: 382135



**18-5200
CONDENSER**
Replaces: 580256



**18-5338
CONDENSER**
Replaces: 382136



**18-5344
CONDENSER**
Replaces: 382125



**18-5345
CONDENSER**
Replaces: 380537



**18-5347
CONDENSER**
Replaces: 980894, 987895



**18-5403
ROTOR**
Replaces: 982880



**18-5404-1
ROTOR**
Replaces: 982211



























**18-5405
ROTOR**
Replaces: 3854549
V-8
Fits new GM style "Module in Cap"



**18-5406
ROTOR**
Replaces: 986651
Use with 18-5361
Distributor Cap



**18-5407
ROTOR**
Replaces: 980892

 <p>18-5408 ROTOR Replaces: 3854311 V-6 Fits new GM style "Module in Cap"</p>	 <p>18-5411 ROTOR Replaces: 982342</p>	 <p>18-5413 ROTOR Replaces: 987986</p>	 <p>18-5418 ROTOR Replaces: 384735</p>	 <p>18-5419 ROTOR Replaces: 380542</p>
 <p>18-5301 TUNE-UP KIT Replaces: Fits: male cap v-8 flamethrower distributors</p>	 <p>18-5302 TUNE-UP KIT Replaces: Fits: male cap v-8 flamethrower distributors</p>	 <p>18-5474 DISTRIBUTOR CAP Red Distributor Cap with Male Terminals Petronix Dsistributors</p>	 <p>18-5473 DISTRIBUTOR CAP Black Distributor Cap w/ Male Terminals Petronix Dsistributors</p>	 <p>18-5248 DISTRIBUTOR CAP OMC 3854217 Fits: OMC 5.0L(1994-96), 5.8L(1994-96)</p>
 <p>18-5352 DISTRIBUTOR CAP Replaces: 984401 Prestolite</p>	 <p>18-5353 DISTRIBUTOR CAP Replaces: 984398 Prestolite</p>	 <p>18-5354 DISTRIBUTOR CAP Replaces: 3854548 V-8 Fits new GM style "module in cap"</p>	 <p>18-5361 DISTRIBUTOR CAP Replaces: 986643</p>	 <p>18-5362 DISTRIBUTOR CAP Replaces: 3854331 V-6 Fits new GM style "Module in Cap"</p>
 <p>18-5369 DISTRIBUTOR CAP Replaces: 982336 w/Gasket 18-5399</p>	 <p>18-5375 DISTRIBUTOR CAP Replaces: 382133</p>	 <p>18-5376 DISTRIBUTOR CAP Replaces: 982209</p>	 <p>18-5384 DISTRIBUTOR CAP Replaces: 383587</p>	 <p>18-5385 DISTRIBUTOR CAP Replaces: 380541</p>
 <p>18-5386 DISTRIBUTOR CAP Replaces: 980152</p>	 <p>18-5397 DISTRIBUTOR CAP</p>	 <p>18-5107-1 IGNITION MODULE Replaces: 3854003 4/6/8 cyl</p>	 <p>18-5464 IGNITION MODULE Fits: Sierra 18-5481, 18-5482 and 18-5483 Billet HI-PERFORMANCE ELECTRONIC DISTRIBUTORS (except HEI/EST)</p>	 <p>18-5108 SENSOR (Pick-Up Coil) Replaces: 3854001, 986642 4, V-6 and V-8 cyl.</p>

APPLICATION BEGINS ON PAGE 750



FEATURES

- ★ Oil filled for better cooling and long life
- ★ Low resistance and improved turn ratios produces the higher voltage needed to run larger spark plug gaps for added power and better fuel economy
- ★ More windings maximize energy and reliability over the full RPM range
- ★ Fits existing brackets for easy installation

 <p>18-5466 HI-PERFORMANCE IGNITION COIL 1.5 ohm (oil filled), black - 8 cylinder: Flame-Thrower 40,000 volt coil. ★ Designed for use with the original Ignitor Electronic Conversion Kits ★ Can be used with other inductive ignition systems</p>	 <p>18-5469 HI-PERFORMANCE IGNITION COIL 3.0 ohm (oil filled), black - 4 & 6 cylinder: Flame-Thrower 40,000 volt coil. ★ Designed for use with the original Ignitor Electronic Conversion Kits ★ Can be used with other inductive ignition systems</p>	 <p>18-5472 HI-PERFORMANCE IGNITION COIL 0.6 ohm (oil filled), black - 4, 6, & 8 cylinder:Flame-Thrower 45,000 volt coil. ★ Super low 0.6 ohm resistance coil designed for use with the Ignitor II Hi Performance Electronic Conversion Kits ★ Compatible with capacitive discharge systems</p>
--	---	---

Part #	Description	Recommended Coil	Resistance Ohms	Part #	Description	Recommended Coil	Resistance Ohms
18-5293-1	Electronic Conversion Kit	18-5469	3.0	18-5288	Hi Performance Electronic Conversion Kit	18-5472	0.6
18-5294	Electronic Conversion Kit	18-5469	3.0	18-5289	Hi Performance Electronic Conversion Kit	18-5472	0.6
18-5295	Electronic Conversion Kit	18-5469	3.0	18-5290	Hi Performance Electronic Conversion Kit	18-5472	0.6
18-5296-2	Electronic Conversion Kit	18-5466	1.5	18-5481	Flame-Thrower Distributor	18-5472	0.6
18-5298	Electronic Conversion Kit	18-5466	1.5	18-5482	Flame-Thrower Distributor	18-5472	0.6
18-5299	Electronic Conversion Kit	18-5466	1.5	18-5483	Flame-Thrower Distributor	18-5472	0.6
18-5286	Hi Performance Electronic Conversion Kit	18-5472	0.6				



**18-5433
IGNITION COIL**
Replaces: 915735
Uses External Resistor
For: 3.0L (1991 & up), 5.7 EFI (1996 & up) and 7.4L EFI (1995 & up)



**18-5437
IGNITION COIL**
Replaces: 383444, 378231
Metal Encased - 12 Volt
Uses External Resistor (For All Applications)
For: 1990 & prior stern drives with breaker point ignition



**18-5443
IGNITION COIL**
Replaces: 3854002
4 cyl./V-8
For: 3.0L (1991 & up), 5.7 EFI (1996 & up) & 7.4 EFI (1995 & up)



**18-5888
SHIFT ASSIST MODULE & HARNESS**
Replaces: 987738
For: V-8 Sterndrives
Fits: 5.0, 5.7 GM (1986-90) 7.5 460 Ford (1987-91)



**18-5889
SHIFT ASSIST MODULE & HARNESS**
Replaces: 987739
For: V-8 Sterndrives
Fits: 5.0, 5.8 Ford (1986-90)



**18-5890
SHIFT ASSIST MODULE & HARNESS**
Replaces: 987740
Fits: 2.3, 3.0, 4.3 (1986-90) & 2.5 (1986)

APPLICATION BEGINS ON PAGE 750



FEATURES

- ★ Senses current levels in the coil and adjusts the dwell to maintain peak energy throughout the entire RPM range.
- ★ Develops, on average, 4 times more available energy between 3000 and 5000 RPM's and twice as much plug voltage as point-type systems.
- ★ Ignition energy is sustained and coil life is increased when peak current level is reached just prior to spark.
- ★ More stable timing.
- ★ Use with 18-5472 "Flame Thrower II" Coil for optimum performance



18-5285
HI-PERFORMANCE
ELECTRONIC CONVERSION KIT
 Fits: 4 Cylinder Delco Distributors



18-5286
HI-PERFORMANCE
ELECTRONIC CONVERSION KIT
 Fits: 6 Cylinder Delco Distributors



18-5287-1
HI-PERFORMANCE
ELECTRONIC CONVERSION KIT
 Fits: Fits: 6 Cylinder Prestolite Distributors



18-5288
HI-PERFORMANCE
ELECTRONIC CONVERSION KIT
 Fits: Most Prestolite V-8 Distributors with snap down cap



18-5289
HI-PERFORMANCE
ELECTRONIC CONVERSION KIT
 Fits: Most Prestolite V-8 Distributors with screw down cap



18-5290
HI-PERFORMANCE
ELECTRONIC CONVERSION KIT
 Fits: Most Mallory YL or YD 8 cylinder Distributors with clockwise and counter clockwise rotation



FEATURES

- ★ Replaces points & condensers for true solid state ignition.
- ★ Uses standard coil, cap and rotor.
- ★ Easy to install, one-piece, 2-wire hook-up.
- ★ Accurate to within 1/4° timing accuracy 0 to 6000 RPM range.

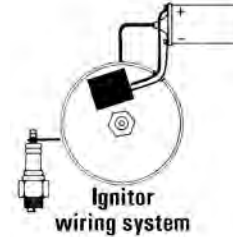

Not compatible with shift assist modules



18-5293-1
ELECTRONIC CONVERSION KIT
 For: All Chevrolet V-6 Prestolite with screw down caps



18-5294
ELECTRONIC CONVERSION KIT
 Fits: 6 Cyl. Delco distributors



18-5295
ELECTRONIC CONVERSION KIT
 Fits: Most 4 Cyl. Prestolite distributors (except IBM 7026)
 For: Onan, Universal, Waukesha, Wisconsin

Not compatible with shift assist modules

APPLICATION BEGINS ON PAGE 750

① 18-5296-2D Display Package



**18-5296-2
ELECTRONIC
CONVERSION KIT**
Fits: Most Mallory YL & YD 8 cyl.
Distributors with clockwise and counter
clockwise rotation

① 18-5297D Display Package



**18-5297
ELECTRONIC
CONVERSION KIT**
For 4 Cyl. GM

① 18-5298 Display Package



**18-5298
ELECTRONIC
CONVERSION KIT**
(with snap down cap)
For: Most Prestolite V-8 Distributors

① 18-5299D Display Package



**18-5299
ELECTRONIC
CONVERSION KIT**
(with screw down cap)
For: Most Prestolite V-8 Distributors
Use with 18-5403 style rotor

Not compatible with shift assist modules



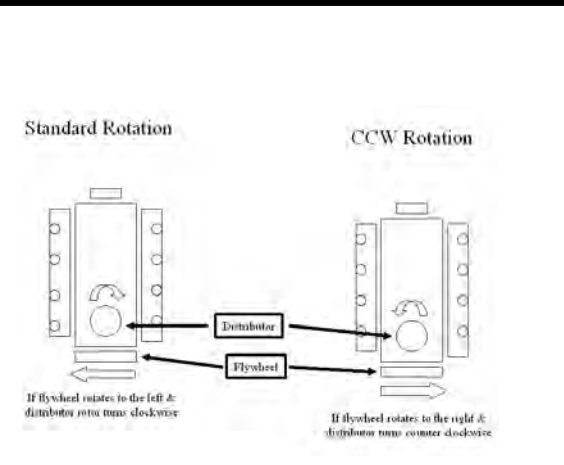

FEATURES

- ★ *Distributors feature the Ignitor II ignition module with adaptive dwell control adjusts the spark timing over the entire RPM range to maximize performance*
- ★ *Upper roller bearing and oil impregnated bronze sintered bottom bushing are installed and aligned bored for accuracy for maximum durability*
- ★ *Machined heat treated gear with tight tolerances insures durability and consistent timing to maximize horsepower and performance. Complete with high dielectric strength cap and rotor for years of performance*





**18-5481
HI-PERFORMANCE
ELECTRONIC
DISTRIBUTOR**
Fits: Ford V-8 351 Windsor
Replacement cap/rotor kit: 18-5266

**18-5482
HI-PERFORMANCE
ELECTRONIC
DISTRIBUTOR**
Fits: Ford V-8 351 Cleveland, 351M, 400,
429 and 460 engines
Replacement cap/rotor kit: 18-5266



**18-5483
HI-PERFORMANCE
ELECTRONIC
DISTRIBUTOR**
Fits: Chevrolet Marine Small and Big Block
engines (Standard Deck Height)
Replacement cap/rotor kit: 18-5266



**18-5477
ELECTRONIC DISTRIBUTOR**
Fits: Ford 302 V-8 engines



**18-5478
ELECTRONIC DISTRIBUTOR**
Chrysler LA series V-8 engines

APPLICATION BEGINS ON PAGE 750

① Items ending in "D" are Display Packaged - Regular number is Non-Display



18-5479
ELECTRONIC DISTRIBUTOR
GM V-8 engines-reverse rotation



18-5476
DISTRIBUTOR
Fits: GM V-6 engines with Delco EST ignition HEI



18-5486
ELECTRONIC DISTRIBUTOR
Replaces: Mallory YLM673AV
Conventional Rotation
For Chevrolet L4, 153 & 181 CID

—CONTAINS—

Part #	Description
18-5397	Distributor Cap
18-5488	Module
18-5404-1	Rotor



18-5487
ELECTRONIC DISTRIBUTOR
Replaces: Mallory YLM676AV
Conventional Rotation
For Chevrolet L6, 194, 230, 250, 292 CID

—CONTAINS—

Part #	Description
18-5488	Module
18-5404-1	Rotor



18-5489
ELECTRONIC DISTRIBUTOR
Replaces: Mallory YLM554CV
Conventional Rotation
For Ford V8 351W CID

—CONTAINS—

Part #	Description
18-5376	Distributor Cap
18-5488	Module
18-5404-1	Rotor



18-5494-1
ELECTRONIC DISTRIBUTOR
Replaces: Mallory YLM624AV
Conventional Rotation
For Chevrolet all V8 includes 482, 502, 540 CID
(Except 348,409 & Tall Deck Big Block)

—CONTAINS—

Part #	Description
18-5376	Distributor Cap
18-5488	Module
18-5404-1	Rotor



18-5495-1
ELECTRONIC DISTRIBUTOR
Replaces: Mallory YLM512CV
Conventional Rotation
For Ford V8 302 CID

—CONTAINS—

Part #	Description
18-5376	Distributor Cap
18-5488	Module
18-5404-1	Rotor



18-5496-1
ELECTRONIC DISTRIBUTOR
Replaces: Mallory YLM567CV
Conventional Rotation
For Ford V8 351C — 460 CID

—CONTAINS—

Part #	Description
18-5376	Distributor Cap
18-5488	Module
18-5404-1	Rotor



**18-5498-1
ELECTRONIC
DISTRIBUTOR**

Replaces:
Mallory YLM624BV
Reverse Rotation
For Chevrolet all V8 includes 482, 502, 540 CID
(Except 348,409 & Tall Deck Big Block)

—CONTAINS—

Part #	Description
18-5376	Distributor Cap
18-5488	Module
18-5404-1	Rotor



**18-5484-1
ELECTRONIC
DISTRIBUTOR**

Replaces: Mallory YLE624AV

Late HEI

Left Hand Rotation

V8 262-454 & 502 except 348/409 and tall block engines

• Designed as a plug-in replacement for GM-style fuel injection system distributors

—CONTAINS—

Part #	Description
18-5354	Distributor Cap
18-5405	Rotor



**18-5485
ELECTRONIC
DISTRIBUTOR**

Replaces: Mallory YLE624BV

Late HEI

Right Hand Rotation

V8 262-454 & 502 except 348/409 and tall block engines

• Designed as a plug-in replacement for GM-style fuel injection system distributors

—CONTAINS—

Part #	Description
18-5354	Distributor Cap
18-5405	Rotor



**18-5309
DISTRIBUTOR**

Contact Controlled

Replaces: 980902; Mallory YL512CV

For most Ford 302 CID V-8 Eng.

Uses: 18-5251 TUNE-UP KIT And 18-5376 CAP



**18-5312
DISTRIBUTOR**

Contact Controlled

Replaces: 981080; Mallory YL554CV

For most Ford 351 CID V-8 Eng.

Uses: 18-5251 TUNE-UP KIT And 18-5376 CAP



**18-5313
DISTRIBUTOR**

Contact Controlled

Replaces: 985560; Mallory YL624MW

For most GM V-8 Engs. (small & large blocks)

Uses: 18-5251 TUNE-UP KIT And 18-5376 CAP



**18-5315
DISTRIBUTOR**

Contact Controlled

Replaces: Mallory YL673AV

For most GM 4 Cyl. Engines (120 & 140 HP)

Uses: 18-5251 TUNE-UP KIT And 18-5397 CAP



**18-5480
COMPLETE
IGNITION
CONVERSION KIT**

Fits: GM SB & BB with Standard Deck Height

—CONTAINS—

Part #	Description
18-5472	Coil
18-8803-2	Wire Set
18-5483	Distributor

Model	Year	Cyl.	Distributor	Contact Set	Condenser	Dist. Cap	Rotor	Tune-Up Kit	Distributor	Electronic Conv. Kit
2.3L	1987-90	4	Mallory ①	18-5314	18-5338	18-5397	18-5404-1	18-5283 ②	—	—
2.3L	1990	4	Prestolite	18-5303	18-5347	—	18-5403	18-5260	—	—
2.5L	1981-86	4	982351 ④	18-5311	18-5345	18-5385	18-5418	18-5250 18-5268 ②	18-5486 ⑧ ① 18-5315 ⑩	18-5297 ①
3.0L	1982-90	4	982351 ④ ⑦	18-5311	18-5345	18-5385	18-5418	18-5250 18-5268 ②	18-5486 ⑧ ① 18-5315 ⑩	18-5297 ①
3.0L	1990-UP	4	—	—	—	18-5361	18-5406	—	—	—
3.8L	1981-86	6	982846, 983203 ② ⑥	18-5303	18-5347 ③	18-5353	18-5403	18-5262 18-5276 ②	—	—
4.3L	1985-90	6	— ② ⑥	18-5303	18-5347 ③	18-5353	18-5403	18-5262 18-5276 ②	—	—
4.3L	1991-92	6	986855 ②	N/A	N/A	18-5353	18-5403	N/A	—	N/A
5.0L (GM)	1981-88	8	983453 ①	18-5314	18-5338	18-5376	18-5404-1	18-5251 18-5271 ②	18-5494-1 ⑧ ① 18-5498-1 ⑨ ① 18-5313 ⑩	18-5296-2 ①
5.0L (GM)	1983-88	8	IBM-7013C ② ⑥	18-5303	18-5347 ③	18-5352	18-5403	18-5262 18-5275 ②	18-5494-1 ⑧ ① 18-5498-1 ⑨ ① 18-5313 ⑩	18-5299 ①
5.0L (GM)	1979-82	8	— ② ⑤	18-5303	18-5347 ③	18-5369	18-5407	18-5258 18-5277 ②	18-5494-1 ⑧ ① 18-5498-1 ⑨ ① 18-5313 ⑩	18-5298
5.0L (Ford)	1989-90	8	— ② ⑥	18-5303	18-5347 ③	18-5352	18-5403	18-5262 18-5275 ②	18-5309 ⑩ 18-5495-1 ⑧	—
5.0L	1991-92	8	— ② ⑥	N/A	N/A	18-5352	18-5403	N/A	18-5309 ⑩	18-5299
5.0L (Ford)	1993	8	Ford	N/A	N/A	—	18-5413	N/A	—	—
5.7L	1982-90	8	983453 ①	18-5314	18-5338	18-5376	18-5404-1	18-5251 18-5271 ②	18-5494-1 ⑧ ① 18-5498-1 ⑨ ① 18-5313 ⑩	18-5296-2 ①
5.7L	1982-90	8	IBM-7013C ② ⑥	18-5303	18-5347 ③	18-5352	18-5403	18-5262 18-5275 ②	18-5494-1 ⑧ ① 18-5498-1 ⑨ ① 18-5313 ⑩	18-5299 ①
5.7L	1991-92	8	— ② ⑥	N/A	N/A	18-5352	18-5403	N/A	18-5494-1 ⑧ 18-5498-1 ⑨ 18-5313 ⑩	N/A
5.8L (Ford)	1989-90	8	— ② ⑥	18-5303	18-5347 ③	18-5352	18-5403	18-5262 18-5275 ②	18-5489 ⑧ 18-5312 ⑩	18-5299
5.8L (Ford)	1991-92	8	— ② ⑥	N/A	N/A	18-5352	18-5403	N/A	18-5496-1 ⑧ 18-5312 ⑩	18-5299
5.8L (Ford)	1993	8	Ford	N/A	N/A	—	18-5413	N/A	—	—
7.5L	1987	8	— ② ⑤	18-5303	18-5347 ③	18-5369	18-5407	18-5258 18-5277 ②	18-5496-1 ⑧ 18-5312 ⑩	18-5298
7.5L	1987-89	8	— ② ⑥	18-5303	18-5347 ③	18-5352	18-5403	18-5262 18-5275 ②	18-5496-1 ⑧ 18-5312 ⑩	18-5299
88	1962-68	4	—	18-5157	18-5200	—	—	18-5001	—	—
90	1962-68	4	—	18-5157	18-5200	—	—	18-5001	—	—
100	1972-73	4	384720, 979856, 980500, 982351 ④	18-5311	18-5345	18-5385	18-5418	18-5250 18-5268 ②	18-5486 ① 18-5315 ⑩	18-5297
110	1964	4	— ④	18-5311	18-5345	18-5385	18-5418	18-5250 18-5268 ②	18-5486 ① 18-5315 ⑩	18-5297
120	1965-86	4	383581, 384258 ④	18-5311	18-5345	18-5385	18-5418	18-5250 18-5268 ②	18-5486 ① 18-5315 ⑩	18-5297 ①
140	1973-89	4	980500, 982351 ④	18-5311	18-5345	18-5385	18-5418	18-5250 18-5268 ②	18-5486 ① 18-5315 ⑩	18-5297 ①
150	1964-66	6	1110309, 22 ④	18-5310	18-5345	—	18-5419	—	—	—
155	1967-72	6	1110376 ④	18-5310	18-5344	—	18-5419	—	—	—
165	1972-76	6	980156 ④	18-5311	18-5345	18-5386	18-5418	18-5250 18-5269 ②	18-5487 ① 18-5495-1 ⑧	—
170	1974	8	— ② ⑤	18-5303	18-5347 ③	18-5369	18-5407	18-5258 18-5277 ②	18-5495-1 ⑧ 18-5309 ⑩	18-5298
175	1975-77	8	980902 ② ⑤	18-5303	18-5347 ③	18-5369	18-5407	18-5258 18-5277 ②	18-5495-1 ⑧ 18-5309 ⑩	18-5298
185	1967-68	8	381775 ①	18-5314	18-5338	18-5375	18-5411	18-5256 18-5272 ②	18-5495-1 ⑧ 18-5309 ⑩	—
185	1978-80	8	981659 ①	18-5314	18-5338 ③	18-5376	18-5404-1	18-5251 18-5271 ②	18-5495-1 ⑧ 18-5309 ⑩	18-5296-2
185	1978-80	8	982320 ② ⑤	18-5303	18-5347	18-5369	18-5407	18-5258 18-5277 ②	18-5495-1 ⑧ 18-5309 ⑩	18-5298
190	1974-77	8	980902 ② ⑤	18-5303	18-5347 ③	18-5369	18-5407	18-5258 18-5277 ②	18-5495-1 ⑧ 18-5309 ⑩	18-5298
200	1966	8	— ④	18-5310	18-5345	18-5384	—	18-5270 ②	18-5494-1 ⑧ 18-5498-1 ⑨ 18-5313 ⑩	—
200	1967-68	8	1111050, 058 053, 382127 ④	18-5310	18-5344	18-5384	—	18-5252 18-5270 ②	18-5494-1 ⑧ 18-5498-1 ⑨ 18-5313 ⑩	—
200	1979-88	8	981659 ①	18-5314	18-5338	18-5376	18-5404-1	18-5251 18-5271 ②	18-5494-1 ⑧ 18-5498-1 ⑨ 18-5313 ⑩	18-5296-2
200	1979-82	8	982320 ② ⑤	18-5303	18-5347 ③	18-5369	18-5407	18-5258 18-5277 ②	18-5494-1 ⑧ 18-5498-1 ⑨ 18-5313 ⑩	18-5298
210	1968-72	8	381775 ①	18-5314	18-5338	18-5375	18-5411	18-5256 18-5272 ②	18-5494-1 ⑧ 18-5498-1 ⑨	—
215	1971	8	— ①	18-5314	18-5338	18-5375	18-5411	18-5256 18-5272 ②	18-5494 ⑧ 18-5498 ⑨ 18-5313 ⑩	—
								18-5251	18-5494-1 ⑧	

N/A Not applicable
 ① Mallory
 ② Prestolite
 ③ For wire lead type, use 18-5345
 ④ Delco
 ⑤ Models w/distributor cap hold down spring clip
 ⑥ Models w/distributor cap hold down screw
 ⑦ '90 Models point ignition only
 ⑧ Electronic distributor (standard rotation)
 ⑨ Electronic distributor (counter rotation)
 ⑩ Contact controlled distributor
 ① Does not include models with shift assist module
 ② With distributor cap

Model	Year	Cyl.	Distributor	Contact Set	Condenser	Dist. Cap	Rotor	Tune-Up Kit	Distributor	Electronic Conv. Kit
225	1978	8	981659, 982320 ①	18-5314	18-5338	18-5376	18-5404-1	18-5271 ②	18-5498-1 ⑨ 18-5313 ⑩	18-5296-2
225	1972-76	8	381775 ①	18-5314	18-5338	18-5375	18-5411	18-5256 18-5272 ②	18-5494-1 ⑧ 18-5498-1 ⑨ 18-5313 ⑩	18-5296-2
230	1979-88	8	981659 ①	18-5314	18-5338	18-5376	18-5404-1	18-5251 18-5271 ②	18-5494-1 ⑧ 18-5498-1 ⑨ 18-5313 ⑩	18-5296-2
230	1979-82	8	982320 ② ⑤	18-5303	18-5347 ③	18-5369	18-5407	18-5258 18-5277 ②	18-5494-1 ⑧ 18-5498-1 ⑨ 18-5313 ⑩	18-5298
230 I.B.	1975-76	8	381775 ①	18-5314	18-5338	18-5375	18-5411	18-5256 18-5272 ②	18-5494-1 ⑧ 18-5498-1 ⑨ 18-5313 ⑩	—
235	1971	8	— ①	18-5314	18-5338	18-5375	18-5411	18-5256 18-5272 ②	18-5494-1 ⑧ 18-5498-1 ⑨ 18-5313 ⑩	—
235	1975-77	8	981080 ② ⑤	18-5303	18-5347 ③	18-5369	18-5407	18-5258 18-5277 ②	18-5494-1 ⑧ 18-5498-1 ⑨ 18-5313 ⑩	18-5296-2
240	1978	8	981080 ② ⑤	18-5303	18-5347 ③	18-5369	18-5407	18-5258 18-5277 ②	18-5494-1 ⑧ 18-5498-1 ⑨ 18-5313 ⑩	18-5296-2
245	1972-75	8	381775 ①	18-5314	18-5338	18-5375	18-5411	18-5256 18-5272 ②	18-5494-1 ⑧ 18-5498-1 ⑨ 18-5313 ⑩	—
250 I.B.	1970-74	8	— ①	18-5314	18-5338	18-5375	18-5411	18-5256 18-5272 ②	18-5494-1 ⑧ 18-5498-1 ⑨ 18-5313 ⑩	—
250	1979	8	981080 ② ⑤	18-5303	18-5347 ③	18-5369	18-5407	18-5258 18-5277 ②	18-5494-1 ⑧ 18-5498-1 ⑨ 18-5313 ⑩	18-5298
260 I.B.	1975-76	8	384193 ①	18-5314	18-5338	18-5375	18-5411	18-5256 18-5272 ②	18-5494-1 ⑧ 18-5498-1 ⑨ 18-5313 ⑩	—
260	1979-82	8	981659 ①	18-5314	18-5338	18-5376	18-5404-1	18-5251 18-5271 ②	18-5494-1 ⑧ 18-5498-1 ⑨ 18-5313 ⑩	18-5296-2
260	1979-82	8	982320 ② ⑤	18-5303	18-5347 ③	18-5369	18-5407	18-5258 18-5277 ②	18-5494-1 ⑧ 18-5498-1 ⑨ 18-5313 ⑩	18-5298
262 CID	1989	6	— ② ⑥	18-5303	18-5347 ③	18-5353	18-5403	18-5262 18-5276 ②	—	—
290 Jet	1974-75	8	— ①	18-5314	18-5338	18-5375	18-5411	18-5256 18-5272 ②	18-5494-1 ⑧ 18-5498-1 ⑨ 18-5313 ⑩	—
305 I.B.	1977-79	8	980680 ①	18-5314	18-5338	18-5375	18-5411	18-5256 18-5272 ②	18-5494-1 ⑧ 18-5498-1 ⑨ 18-5313 ⑩	—
305 I.B.	1980-82	8	981659, 982320 ①	18-5314	18-5338	18-5376	18-5404-1	18-5251 18-5271 ②	18-5494-1 ⑧ 18-5498-1 ⑨ 18-5313 ⑩	18-5296-2
350 I.B.	1977-79	8	981659 ①	18-5314	18-5338	18-5375	18-5411	18-5256 18-5272 ②	18-5494-1 ⑧ 18-5498-1 ⑨ 18-5313 ⑩	—
350 I.B.	1980-82	8	982320 ①	18-5314	18-5338	18-5376	18-5404-1	18-5251 18-5271 ②	18-5494-1 ⑧ 18-5498-1 ⑨ 18-5313 ⑩	18-5296-2
350 CID	1988-89	8	— ⑥	18-5314	18-5338	18-5376	18-5404-1	18-5251 18-5271 ②	—	—
350 CID	1988-89	8	— ② ⑤	18-5303	18-5347 ③	18-5352	18-5403	18-5275 ②	18-5313 ⑩ — 18-5313 ⑩	—
454 I.B.	1977-79	8	— ①	18-5314	18-5338	18-5375	18-5411	18-5256 18-5272 ②	18-5494-1 ⑧ 18-5498-1 ⑨ 18-5313 ⑩	—
454 I.B.	1980-82	8	981659, 982320 ①	18-5314	18-5338	18-5376	18-5404-1	18-5251 18-5271 ②	18-5494-1 ⑧ 18-5498-1 ⑨ 18-5313 ⑩	18-5296-2
460 CID	1988-89	8	— ② ⑥	18-5303	18-5347 ③	18-5352	18-5403	18-5262 18-5275 ②	—	—

N/A Not applicable

- ① Mallory
- ② Prestolite
- ③ For wire lead type, use 18-5345
- ④ Delco

- ⑤ Models w/distributor cap hold down spring clip
- ⑥ Models w/distributor cap hold down screw
- ⑦ '90 Models point ignition only
- ⑧ Electronic distributor (standard rotation)

- ⑨ Electronic distributor (counter rotation)
- ⑩ Contact controlled distributor
- Ⓜ Does not include models with shift assist module
- Ⓝ With distributor cap



MP28890
IGNITION LANAYARD
Replaces: 176288
Fits: 1996 - Up



MP28880*
LANAYARD
Replaces: 432230
Fits: 1995-Older



18-5225
SPARK PLUG WIRE KIT
Replaces: Mercury 84-99215A26, 84-813706A26
Kit Includes 25 ft. Roll of 7 MM Hypalon Ignition Wire With a Metallic Core and a Large Assortment of Three Different End Fittings.



18-5226
IGNITION WIRE
 Metallic Core
 100' Spool
 7mm Hypalon

PKG. OF 10



18-5224
18-5224-90
SPARK PLUG WIRE TERMINAL
 Replaces: Mercury 20121
 OMC 510364

PKG. OF 10



18-5750
18-5750-90
UNIVERSAL SPARK PLUG BOOT
 Supplied complete w/Terminal Connector
 Replaces: OMC 581027, 580339



18-5752
UNIVERSAL SPARK PLUG BOOT
 8mm

PREMIUM MARINE SPARK PLUG WIRE LEADS



OE style boots provide a sealed barrier against heat, dirt and moisture.



Premium Marine Wire Leads
 Magnetic Suppression Core
 Manufactured for your specific application

- ★ Kevlar® core for maximum durability and long life.
- ★ Durable stainless steel wound conductor for maximum horsepower and engine performance.
- ★ Premium silicone jacketing and boots for the ultimate in high temperature protection.
- ★ Superior RFI suppression for the most sensitive electronic system.
- ★ Corrosion resistant stainless steel spark plug and distributor terminals for maximum conductivity.

Model	Ignition Type	Cyl.	O.E.M. #	Part #
2.3L	Conventional	4	503747	18-8807-1
100/ 110/ 120/ 2.5L/ 140/ 3.0L/ 140 Jet	Conventional	4	503748	18-8800-1
3.0L/ HO	EST Electronic	4	503749	18-8814-1
3.0L/ HO	EST Electronic	4	503749	18-8811-1
3.0L/ HO	EST Electronic	4	503749	18-8841-1
4.3L	EST Electronic	6	503751	18-8810-1
3.8L/ 4.3L	Conventional	6	503750	18-8801-1
370 (King Cobra)/ 454/ 7.4L/ 502/ 8.2L	Conventional	8	503752, 503755	18-8803-2
175/ 185/ 190/ 200/ 5.0L - 5.7L (GM)	Conventional	8	503752, 503755 ①	18-8803-2, 18-8823-1 ①
225/ 230/ 235/ 240/ 250/ 260	Conventional	8	503752, 503755 ①	18-8803-2, 18-8823-1 ①
5.0L - 5.8L EFI (Ford)	EST Electronic	8	503754	18-8820-1
5.0L - 5.8L (Ford)	Conventional	8	503753	18-8842-1
460 (King Cobra)	Conventional	8	N/A	18-8825-1
8.1L / 496	Distributorless	8		18-8838-1
7.4L / 8.2L V8	DDS	8	503756	18-8843-1

① Models with Mallory side terminal caps

Engine	Cyl.	Year	Kit	Engine	Cyl.	Year	Kit
2.3L	4	1987-90	18-8807-1	185	8	1978-80	18-8802-1
2.5L	4	1982-86	18-8800-1	190	8	1975-77	18-8805-1
3.0L ⑧	4	1982-90	18-8800-1	200	8	1979-81	18-8802-1
3.0L/3.0L H.O.	4	1991-92	18-8814-1	225	8	1978	18-8802-1
3.0L/3.0L H.O. ⑩	4	1990-94	18-8841-1	225	8	1976	18-8802-1
2.5/3.0L 110-140hp ⑩	4	1964-90	18-8811-1	230	8	1979-81	18-8802-1
3.8L	V6	1981-86	18-8801-1	230 IB LH	8	1976	18-8802-1
4.3L ⑨	V6	1985-90	18-8801-1	230 IB LH	8	1976	18-8802-1
4.3L ⑩	V6	1994	18-8810-1	235	8	1975-77	18-8805-1
5.0L	8	1982-88	18-8802-1	240	8	1978	18-8805-1
5.0L	8	1989-90	18-8806-1	250	8	1979	18-8805-1
5.7L	8	1982-89	18-8802-1	260	8	1979-81	18-8802-1
5.7L King Cobra	8	1988	18-8802-1	260 IB LH	8	1976	18-8802-1
5.8L	8	1989-90	18-8842-1	260 IB LH	8	1976	18-8802-1
7.4L ②	8	1991	18-8843-1	262 King Cobra	V6	1989	18-8801-1
7.4L/8.2L	8	1992-94	18-8843-1	305 CID IB LH ⑥	8	1979-82	18-8802-1
7.5L	8	1987	18-8803-2	305 CID IB RH ⑤	8	1977-82	18-8802-1
7.5L King Cobra	8	1987	18-8803-2	305 CID IB RH ⑦	8	1979-82	18-8802-1
80	4	1968-69	18-8800-1	305 CID IB LH ⑤	8	1977-82	18-8802-1
100	4	1972-73	18-8800-1	350 CID IB RH ⑤	8	1977-82	18-8802-1
110	4	1964	18-8800-1	350 CID IB RH ⑦	8	1979-82	18-8802-1
120 ①	4	1965-74	18-8800-1	350 King Cobra	8	1989	18-8802-1
120 ②	4	1974-81	18-8800-1	370 King Cobra	8	1988	18-8803-2
140 ①	4	1973-74	18-8800-1	454 CID IB	8	1979-82	18-8802-1
140 ②	4	1974-81	18-8800-1	460 King Cobra	8	1988-89	18-8803-2
140 Jet	4	1973	18-8800-1	8.1L / 496 ①	8	2000 & up	18-8838-1
175	8	1975-77	18-8805-1				

③ Priced per Package



Display Package

SPARK PLUG WIRE SETS
 8mm

- ① 1974:FF and R only
- ② 1974:Model R1 only
- ③ 1975:Model A1 only
- ④ Model M only
- ⑤ Models w/o closed cooling
- ⑥ V-Drive model w/ closed cooling
- ⑦ Direct Drive Model w/ closed cooling
- ⑧ 1990 Models 302BMRPWS and 302BPRPWS
- ⑨ 1990 (2 BBL) carb
- ⑩ Delco Digital & EST Ignition
- ① Distributorless Ignition
- ② F suffix models only



18-5923
STARTER, PMGR, FORD
 PMGR Replacement for 18-5903;
 302CID, 351CID Ford Engines



18-5927
STARTER, PMGR, FORD
 PMGR Replacement for 18-5917, 2.3L
 Ford Starter.



18-6834
STARTER
 Replaces: GM Engines Universal
 Used on Buick, Chevrolet, Oldsmobile, and Pontiac Race
 Engines



18-6835
STARTER
 Replaces: GM Engines Universal
 Used on Buick, Chevrolet, Oldsmobile, and Pontiac Race
 Engines



18-6270
PERMANENT MAGNET I/O STARTER
 Replaces: 988013,
 984536
 • Permanent Magnet
 • Heavy Duty
 • 12 Volt
 • 2 Bolt Mount
 • 1 Threaded Hole
 • CW Rotation
 • SAE J1171
 For: 460 Ford, OMC King Cobra



18-5919
STARTER
 Permanent magnet I/O starter
For: Late model GM - 12 3/4" flywheel
 Replaces: 988217
 Replacement Solenoid: 18-6287
 SAEJ1171
 1.7 KW



18-5920
STARTER
 Permanent Magnet
For: 5.0 & 5.8 litre Ford engines.
 Replaces: 987811, 3854190
 Replacement Solenoid: 18-6291

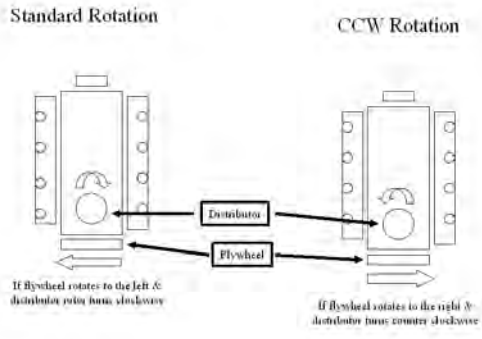

18-6276
STARTER
 Replaces: 984536, 988013
 • 12 Volt
 • CW Rotation
 • Threaded Top Hole in Housing
 • 460 Ford, OMC King Cobra



18-5911
STARTER

(Heavy-Duty) (No Core)
 For GM engines, bottom mount straight across bolt pattern.
 Standard rotation clockwise. 100-245 HP — 1970-1978 (GM)
 Replaces: 981078, 982121, 983444, 983790, 985966
 Replacement Solenoid: 18-5837
 SAEJ1171



18-5900
REMANUFACTURED
STARTER



18-5907
STARTER

(Heavy-Duty) (No Core)
 Top mount rear entry starter for opposite rotation
 GM and Ford engines clockwise.
 Replaces: 981289, 982202
 Replacement Solenoid: 18-5837
 SAEJ1171



18-5901
REMANUFACTURED
STARTER





**18-5908
STARTER**

(Heavy-Duty) (No Core)
Top mount rear entry starter for standard rotation
GM and Ford engines. Counter-clockwise.
Replaces: 981288, 982195, 984982, 986007
Replacement Solenoid: 18-5837
SAEJ1171



**18-5902
REMANUFACTURED
STARTER**



**18-5910
STARTER**

(Heavy-Duty) (No Core)
Small block GM V-6 & V-8 Engine with 14 1/4" flywheel and bottom
mount, offset bolt pattern. For standard rotation engines. Clock-
wise. 1986-1992 - V-6, V-8 (GM) and 1990-1993 OMC King Cobra
Replaces: 984456, 986505
Replacement Solenoid: 18-5837
SAEJ1171



**18-5905
REMANUFACTURED
STARTER**



**18-5917
STARTER**
Replaces: 984628
3 bolt mount - Late style 4" diameter case.
Standard rotation engines For: Late model
Ford V-8. Replacement Solenoid: 18-5801



**18-5903
STARTER**
(No Core) (Clockwise)
Bottom mount, two bolt pattern for stan-
dard rotation. Ford engines. Clockwise
Replaces: 980803, 981821
Replacement Solenoid: 18-5801



**18-5913
STARTER**
(Clockwise)
Delco permanent magnet gear reduction
2 bolt starter 12V - 11 Tooth - Offset bolt
pattern. Fits: Chevy Engines with 14"
flywheels. 1.7 KW
Replaces: 3854751 SAEJ1171
Replacement Solenoid: 18-6287



OMC STERNDRIVE/OMC COBRA STARTERS

Engine	Year	Starter #	Engine	Year	Starter #	Engine	Year	Starter #
3.0L	1982-92	18-5900	170	1974	18-5903	245	1972-75	18-5900
5.0L	1982-86	18-5900 ④	175	1975-77	18-5903	245 JET	1972-74	18-5900
5.0L	1986-88	18-5905 ⑤	185	1967-68,		250	1979	18-5903
2.5L	1982-86	18-5900		1978-80	18-5900	260	1975-76	18-5902 ①
3.8L	1981-86	18-5900	190	1974-77	18-5903	260	1975-76	18-5901 ②
4.3L	1985-86	18-5900	200	1966-68,		260	1979-81	18-5900
4.3L	1986-92	18-5905		1979-81	18-5900	262 CID	1989	18-5905
5.7L	1982-86	18-5900	210	1968-72	18-5900 ①	290	1975	18-5902 ③
5.7L	1986-92	18-5905	215	1971	18-5900	305 CID	1977-80,82	18-5902 ①
100	1972-73	18-5900	225	1972-76,		305 CID	1977-80,82	18-5901 ②
110	1964	18-5900		1978	18-5900 ①	350 CID	1977-80,82	18-5902 ①
120	1965-81	18-5900	230	1975-76	18-5902 ①	350 CID	1977-80,82	18-5901 ②
140	1973-81	18-5900	230	1975-76	18-5901 ②	350 CID	1988-91	18-5905
140 JET	1973	18-5900	230	1979-81	18-5900	370 CID	1988	18-5902
150	1964-66	18-5900	235	1971	18-5900	454 CID	1977-80,82	18-5902 ①
155	1967-72	18-5900	235	1975-77	18-5903	454 CID	1977-80,82	18-5901 ②
165	1972-76	18-5900	240	1978	18-5903	454 CID	1990-92	18-5905
						502 CID	1992	18-5905

① Standard rotation engines.

② Opposite (Reverse) rotation engines.

③ Engines with model number suffix "R2" or "R3"

④ '86 Model engines with model number suffix "WB"

⑤ '86 Model engines with model number suffix "XS"



**18-5717
STARTER BRUSH SET**
Replaces:
Delco 1984462



**18-5811
STARTER SOLENOID**
Replaces: 3850216
For: PG 260 series starters, GM V6 & V8 (1983-Up)



**18-5801
SOLENOID**
Replaces: 985064
Grounded Base

① 18-5801D Display Package

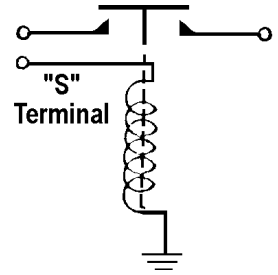
**18-5803
SOLENOID**
Replaces: 979774

**18-5807
SOLENOID**
Replaces: 378444
Prestolite SAW4206

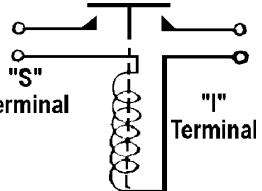

**18-6291
SOLENOID**
Replaces: 3854194 and Volvo Penta 3854194-2
Fits: Ford Gear Reduction Starters on Late Model 5.0L, 5.8L, OMC and Volvo Penta



**18-5814
SOLENOID**
Replaces: 172869, 581528
12 Volt, Isolated Base





**18-5808
SOLENOID**
Replaces: 395419, 582708

③ 18-5808D Display Package

**18-5812
SOLENOID**
Replaces: 985063

③ 18-5812D Display Package

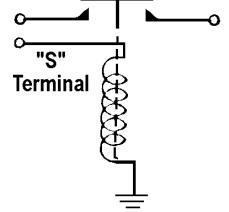
**18-5837
SOLENOID**
Replaces: 985799, 986620
Delco 1114531

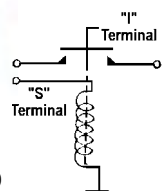

**18-5838
SOLENOID**
Replaces:
Delco 1114356, 1114458



BATTERY CABLES
Gauge cable with soldered lug terminals on each end to accept a 3/8" stud

Part No.	Size	Color	Gauge	Part No.	Size	Color	Gauge
BC88523	2'	red	4	BC88563	6'	red	2
BC88533	2'	black	4	BC88573	6'	black	2
BC88543	4'	red	2	BC88583	8'	red	1
BC88553	4'	black	2	BC88593	8'	black	1

① Items ending in "D" are Display Packaged - Regular number is Non-Display

STRINGER SOLENOID APPLICATION

HP	Year	Starter Brush	Starter Mounted Solenoid	Starter Solenoid	Tilt Solenoid	Trim Solenoid
80	1969	—	N/A	18-5808	N/A	18-5808
88	1964	—	N/A	18-5807	N/A	18-5807
90	1965-71	—	N/A	18-5808	N/A	18-5808
100	1972-73	18-5717	18-5838	18-5803	N/A	18-5803
110	1964	18-5717	18-5838	18-5807	N/A	18-5807
120	1965-71	18-5717	18-5838	18-5808	N/A	18-5808
120	1972-77	18-5717	18-5838	18-5803	18-5803	18-5803
120	1978-81	18-5717	18-5838	—	—	—
140	1973-77	18-5717	18-5838	18-5803	18-5803	18-5803
140	1978-81	18-5717	18-5838	—	—	—
145	① 1973	—	18-5838	18-5803	N/A	N/A
150	1964	18-5717	18-5838	18-5807	N/A	18-5807
150	1965-66	18-5717	18-5838	18-5808	N/A	18-5808
155	1967-72	18-5717	18-5838	18-5808	N/A	18-5808
165	1972-76	18-5717	18-5838	18-5803	18-5803	18-5803
170	1974	—	N/A	18-5801	N/A	18-5803
175	1975-78	—	N/A	18-5801	N/A	18-5803
185	1967-68	18-5717	18-5838	18-5808	N/A	18-5808
185	1978-80	18-5717	18-5838	—	—	—
190	1974-78	—	N/A	18-5801	N/A	18-5803
200	1966-78	18-5717	18-5838	18-5808	N/A	18-5808
200	1979-81	—	18-5838	—	—	—
210	1968-70	18-5717	18-5838	18-5808	N/A	18-5808
210	② 1970-72	18-5717	18-5838	18-5808	N/A	N/A
215	1971	18-5717	18-5838	18-5808	N/A	18-5808
225	1972	18-5717	18-5838	18-5808	N/A	18-5808
225	1973	18-5717	18-5838	18-5803	N/A	18-5808
225	1974-76	18-5717	18-5838	18-5803	N/A	18-5803
225	1978	18-5717	18-5838	—	—	—
225	② 1973-74	18-5717	18-5838	18-5808	N/A	N/A
230	② 1975-76	18-5717	18-5838	18-5803	N/A	N/A
230	1979-81	18-5717	18-5838	—	—	—
235	1971	18-5717	18-5838	18-5808	N/A	18-5808
235	1975-78	—	N/A	18-5801	N/A	18-5803
245	1972	18-5717	18-5838	18-5808	N/A	18-5808
245	1973	18-5717	18-5838	18-5803	N/A	18-5808
245	1974-75	18-5717	18-5838	18-5803	N/A	18-5803
245	① 1972-75	18-5717	18-5838	18-5808	N/A	N/A
250	② 1970-74	—	18-5838	18-5808	N/A	N/A
260	② 1975-76	18-5717	18-5838	18-5803	N/A	N/A
260	1979-81	18-5717	18-5838	—	—	—
290	① 1974-75	18-5717	18-5838	18-5808	N/A	N/A
305	② 1977-82	18-5717	18-5838	—	N/A	N/A
350	② 1977-82	18-5717	18-5838	—	N/A	N/A
454	② 1977-82	18-5717	18-5838	—	N/A	N/A
2.5	1982	18-5717	18-5838	—	—	—
2.5	1983-86	18-5717	18-5837	—	—	—
3	1982	18-5717	18-5838	—	—	—
3	1983-86	18-5717	18-5837	—	—	—
3.8	1981-82	18-5717	18-5838	—	N/A	—
3.8	1983-86	18-5717	18-5837	—	N/A	—
4.3	1985-86	18-5717	18-5837	—	N/A	—
5	1982	18-5717	18-5838	—	—	—
5	1983-86	18-5717	18-5837	—	—	—
5.7	1982	18-5717	18-5838	—	—	—
5.7	1983-86	18-5717	18-5837	—	—	—

① Jet Drive ② Inboard

OMC COBRA SOLENOID APPLICATION

HP	Year	Starter Brush	Starter Mounted Solenoid	Starter Solenoid	Trim Solenoid
262	1989	N/A	18-5837	18-5812	N/A
350	1988	N/A	18-5837	18-5812	18-5812
350	1989	N/A	18-5837	18-5812	N/A
350	1990-91	N/A	18-5837	18-5801	N/A
351	1992	—	—	18-5801	N/A
370	1988	N/A	—	18-5812	18-5812
370	1989	N/A	—	18-5812	N/A
454	1990	—	—	18-5801	N/A
454	1991-92	N/A	18-5837	18-5801	N/A
460	1989-90	N/A	—	18-5801	N/A
502	1992	N/A	18-5837	18-5801	N/A
2.3	1987-88	N/A	—	18-5801	18-5812
2.3	1989-90	N/A	—	18-5801	N/A
2.5	1986	18-5717	18-5837	18-5812	18-5812
3	1986-88	18-5717	18-5837	18-5812	18-5812
3	1989-90	18-5717	18-5837	18-5812	N/A
3	1991-92	18-5717	18-5837	18-5801	N/A
4.3	1986-88	18-5717	18-5837	18-5812	18-5812
4.3	③ 1989-90	18-5717	18-5837	18-5812	N/A
4.3	④ 1990-92	18-5717	18-5837	18-5801	N/A
5	1986-88	18-5717	18-5837	18-5812	18-5812
5	1989-92	18-5717	—	18-5801	N/A
5.7	1986-88	18-5717	18-5837	18-5812	18-5812
5.7	1989	18-5717	18-5837	18-5812	N/A
5.7	1990-92	18-5717	18-5837	18-5801	N/A
5.8	1989-92	N/A	—	18-5801	N/A
7.5	1987	18-5717	—	18-5801	18-5812

③ 1990 Models with 2 barrel carbs ④ 1990 Models with 4 barrel carbs.

18-5711
VOLTAGE REGULATOR
 Replaces: 383440
 Prestolite: VSH-6201 AFY
 12 Volt



Years	Model	Alternator or Generator
1964-66	110, 150 HP	ALK-6222, A, AYS
1967-81	80, 90, 120, 140, 155, 165, 175 185, 190, 200, 210, 225, 230, 235, 250, 260 HP & 305, 350, 454 CID	ALK-6222, A, AY, Y, AYS ANK-65201S, Y ALK-6210, A

18-6261
ALTERNATOR
 Replaces: 987774, 3857561,
 3854182, 3854809, 3856600, 3860171
 Fits: 3.0L, 4.3L, 5.7L, 7.4L (1995-98), 5.0L, 5.8L, 8.2L
 (1993-98)
 For: Delco



18-6260
ALTERNATOR
 OMC Cobra 12 Volt, 51 Amp, Internal
 Regulator, Negative Ground, Single
 Groove Pulley For : Prestolite/Motorola



18-6841
ALTERNATOR
 Replaces: 983836, 988247
 For: 37-63A Marine Applications



18-6842
ALTERNATOR
 Replaces: 983424, 836, 247
 For: 37-63A Marine Applications



18-5957
ALTERNATOR



18-5951
ALTERNATOR
 Remanufactured



Replaces: 982364, 983424, 983836, 985466, 986008
 (3-Wire) (No Core) (68 AMP)

Replaces Mando, Motorola and original equipment Delco. Uses same electrical
 connections and mounting method. Equipped with fan and drive pulley. SAEJ1171



18-2192
ELECTRIC SHIFT CABLE
 Replaces: 379628

ELECTRIC SHIFT CABLE APPLICATION

Year	HP
1964	110 ②, 150
1965	120 ①, 150
1966	120 ①, 150, 200
1967	120 ①, 155, 185, 200
1968	120, 155, 185, 200, 210
1969-70	120, 155, 210
1971	120, 155, 215, 235
1972-73	100, 120, 155, 165, 225, 245
1974	120, 140, 165, 170, 190, 225, 245
1975	120, 140, 165, 175, 190, 225, 235, 245
1976	120, 140, 165, 175, 190, 225, 235
1977	120, 140, 175, 190, 235

① Heavy Duty ② SU12M, SUE 12M

③ **18-5705D**

18-5705
POWER
TRIM RELAY

Replaces: 582472,
 584416, 586224
 5 Terminal



Single Pull - Double Throw - 12 Volt
 Open Contact: 40 Amps Resistive
 30 Amps Conductive
 Closed Contact: 20 Amps Resistive
 15 Amps Conductive



18-6257
TILT/TRIM MOTOR
 Replaces: 983195, 982957
 1982-85 Models with hydraulic engine lifts for
 pump assembly



18-6754
TILT MOTOR
 Replaces: 382138
 Prestolite ETK 4102, ETK 4001, ETK 4101
 (All Models 1963-77)



18-6755
TILT MOTOR
 Replaces: 982706, 982058
 Prestolite EVD 4001, EVD 4002
 (All Models Except 2.5L, 3.0L - 1978-85)



**18-6764
TILT/TRIM MOTOR**
Replaces: 982073, 983318, 982069
For: OMC Stringer and Cobra "Select Trim" 3-Wire Connection 1979-85 Stern Drive (2.5L & 3.0L)

PKG. OF 5



**18-6779
TRIM MOTOR**
Replaces: 986280, 3853945
For: 1990 & 1994 King Cobra Trim System

NEW



**18-6814
TRIM MOTOR**
Replaces: 984356
OMC Cobra

NEW



**18-6816
TRIM MOTOR**
Replaces: 172588, 173944
Fits: 40, 50, 70, and 75HP with short shaft

NEW



**18-6823
WIRING HARNESS**
Replaces: Universal
Converts 3-wire Tilt and Trim motors to 2-Wire design



**18-6950
18-6950-9[Ⓢ]
POWER TILT FUSE
(50 amp)**
Replaces: 982019



**18-9802
TIMING LIGHT**
Self-powered accurate up to 10,000 RPM's



**18-7601
AIR CHARGE
TEMPERATURE SENSOR**
Replaces: 3854158
8 cyl
5.0L, 5.8 L, EFI (1994-96)



**18-7684
MAP SENSOR**
Replace: 3850396
For: 4.3L TBI(1996-98), 5.0L TBI(1998), 5.7L TBI(1996-98), 7.4L(1995-98), 8.2L(1998)



**18-7677
KNOCK SENSOR**
Replace: 3850357



**18-7679
KNOCK SENSOR**
Replace: 3854905



**18-7703
KNOCK SENSOR**
Replace: 3854512



**18-7689
FUEL INJECTOR**
Replace: 3855182



**18-7650
FUEL PRESSURE REGULATOR**
Replaces: 987995
8 cyl
5.0L, 5.8 L, EFI (1993)



**18-7627
INTAKE MANIFOLD**
Small-block GM with vortec cylinder heads



**18-7628
INTAKE MANIFOLD**
Small-block GM with vortec cylinder heads with brass lined water jackets

Ⓢ Priced per Package

ALL SIERRA CARBURETORS INCLUDE BASE GASKET

- Precision remanufactured to meet or exceed OEM specifications
- Re-calibrated and re-engineered to maximize fuel efficiency and performance
- All carburetors are flow tested throughout the entire throttle range
- Fuel mixture and idle settings are pre-set to ensure that only minor idle and choke adjustments are necessary during installation
- All bases are resurfaced and throttle shaft bushings replaced



**18-7635
CARBURETOR
(REMANUFACTURED)**
300 CFM Holley 2V



**18-7636
CARBURETOR
(REMANUFACTURED)**
500 CFM Holley 2V



**18-7637
CARBURETOR
(REMANUFACTURED)**
600 CFM Holley 4V



**18-7638
CARBURETOR
(REMANUFACTURED)**
600 CFM Holley 4V-side inlet



**18-7640
CARBURETOR
(REMANUFACTURED)**
Universal Q-jet with electric choke



**18-7605-1
CARBURETOR**
4 Barrel Rochester
Replaces: 382821, 383766, 384194
Remanufactured



**18-7608-1
CARBURETOR**
2 Barrel Rochester
Replaces: 381668, 980528, 982219, 982217
Remanufactured



**18-7609-1
CARBURETOR**
2 Barrel Rochester
Replaces: 382733, 980530,
982217, 984180, 381494, 772831
Remanufactured



**18-7615-1
CARBURETOR**
4 Barrel Rochester
Replaces: 981705, 982223,
983855, 981359, 981564,
985822, 981803, 981428
Remanufactured



**18-7615N
Q-JET CARBURETOR**
Replaces: 1347-816373A4,
1347-804624R1,
1347-804624R02

OMC STERN DRIVE CARBURETOR APPLICATION

Model	Year	OMC Carburetor #	MFG Carburetor #	Carb Code & Model	Part #
80	1968-69	382733, 772831	7028085, 17059053, 17086064, 17087311	R2, 2GC	18-7609-1
90	1970-71	382733, 772831	7028085, 17059053, 17086064, 17087311	R2, 2GC	18-7609-1
120 (400 Series)	1972-86	381668, 980528, 982219	7044186, 17059056	R2, 2GC	18-7608-1
140 (400 Series)	1973-85	979821, 980530, 982217, 984180	17086107	R2, 2GC	18-7608-1
155	1967-72	772831	7026180	R2, 2GC	18-7609-1
165	1972-76	979821, 980530	17086107	R2, 2GC	18-7609-1
185	1989	984180	17086064	R2, 2GC	18-7609-1
200	1966-68	381494	7025187	R2, 2GC	18-7609-1
210	1968-72	382821, 383766	7028282, 7028280	R4, 4MV	18-7605-1
215, 225, 230	1971-76	382821	7028280	R4, 4MV	18-7605-1
230 (800 Series)	1979-89	981705, 982223	17057290, 17059285, 17059286, 17086117	R4, 4MV	18-7615-1
245	1972-75	384194	7040284	R4, 4MV	18-7605-1
250	1970-74	384194	7040284	R4, 4MV	18-7605-1
260 (800 Series)	1975-76	384194	7040284	R4, 4MV	18-7605-1
260 (800 Series)	1979-89	982223	17057290, 17059285, 17059286, 17086117	R4, 4MV	18-7615-1
2.5L, 3.0L	1982-86	982219, 982217	17059056, 17059053	R2, 2GC	18-7608-1
3.0L	1987-90	984180	17086064	R2, 2GC	18-7608-1
3.8L (4V)	1979-85	983855	17082515, 17085010	R4, 4MV	18-7615-1
4.3L (4V)	1979-89	983855	17082515, 17085010	R4, 4MV	18-7615-1
5.0L (GM)(4V)	1979-89	982223	17057290, 17059285, 17059286, 17086117	R4, 4MV	18-7615-1
5.7L (4V)	1979-89	982223	17057290, 17059285, 17059286, 17086117	R4, 4MV	18-7615-1
305, 350 CI, I/B	1977-83	981359, 982215, 981564, 982223	17057290, 17059285, 17059286, 17086117	R4, 4MV	18-7615-1
350 (4V)	1988-89	985822	17057290, 17059285, 17059286, 17086117	R4, 4MV	18-7615-1
454 CI, I/B	1977-78	981803, 981428	17057290, 17059285, 17059286, 17086117	R4, 4MV	18-7615-1



**18-7017
CARB KIT**
Replaces: 985052
235 (5.8L Ford) 1989 7.5L/460 C.I. 1987-89
(Contains Non-adjustable needles and seats)



**18-7018
CARB KIT**
Replaces: 981790, 982352
350 C.I. Inboard 1977-78



**18-7070
CARB KIT**
Replaces: 383615, 982384



**18-7071
CARB KIT**
Replaces: 380186



**18-7072
CARB KIT**
Replaces: 979659, 384743



**18-7080
CARB KIT**
Replaces: 979719



**18-7081
CARB KIT**
Replaces: 982537, 982538,
(Contains adjustable needles and seats)



**18-7086
CARB KIT**
Replaces: 984487

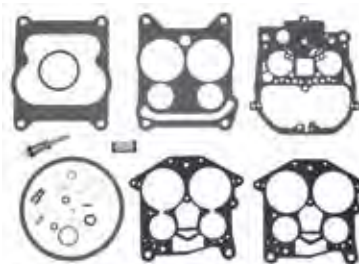

**18-7095
CARB KIT**
Replaces: 983864, 383918



**18-7096
CARB KIT**
Replaces: 982539, 85R-4541
(Contains adjustable needles and seats)



**18-7235
CARB KIT**
Replaces: 986783



**18-7236
CARB KIT**
Replaces: 986782



**18-7237
CARB KIT**
Replaces: 986784, 986799



**18-7238
CARB KIT**
Replaces: 986796



**18-7239
CARB KIT**
Replaces: 986800



**18-7241
CARB KIT**
Replaces: 986804



**18-7242
CARB KIT**
Replaces: 987313



**18-7243
CARB KIT**
Replaces: 987315



**18-7244
CARB KIT**
Replaces: 987317



**18-7245
CARB KIT**
Replaces: 987319



**18-7246
CARB KIT**
Replaces: 987438, 987440, 987485



**18-7727
CARB KIT**



**18-7729
CARB KIT**



**18-7730
CARB KIT**



**18-7200
FLOAT
(Alcohol Resistant)**
Replaces: 381389
Brass



**18-7201
FLOAT
(Alcohol Resistant)**
Replaces: 383087, 983871
Brass



**18-7206
NITROPHYL FLOAT**
Nitrophyl

CARBURETOR KIT/FLOAT APPLICATION

Model	Years	Mfg. Code	Carb. Model	Carb. Kit	Float
80	1968-69	R2	2GC	18-7070	18-7200
90	1970-71	R2	2GC	18-7070	18-7200
100	1972-73	C1	RBS	18-7080	—
110	1964	R1	BC	18-7071	—
120	1965-71 (Dual Carb)	C1	RBS	18-7080	—
120	1972-85	R2	2GC	18-7070	18-7200
140	1973-85	R2	2GC	18-7070	18-7200
150	1964-65	R1	BC	18-7071	—
150	1965-66	C1	RBC	18-7080	—
155	1967-72	R2	2GC	18-7070	—
165	1972-76	R2	2GC	18-7070	18-7200
170	1974	H2	2300	18-7081	18-7206
175	1975-77	H2	2300	18-7081	18-7206
185	1978-81	R2	2GE	18-7086	18-7200
185	1989	H2	2300	18-7081	18-7206
190	1974-77	H2	2300	18-7081	18-7206
200	1966-68	R2	2GC,V	18-7070	—
200	1979-85	R2	2GE	18-7086	18-7200
200	1989	H2	2300	18-7081	18-7206
210	1968-72	R4	4MV	18-7072	18-7201
215	1971	R4	4MV	18-7072	18-7201
225	1972-76	R4	4MV	18-7072	18-7201
230	1975-76	R4	4MV	18-7072	18-7201
230	1979-89	R4	4MV	18-7095	18-7201
235	1975-77	H4	4160	18-7096	18-7206
235	1989	H4	4160	18-7017	—
240	1978	H4	4160	18-7017	—
245	1972-75	R4	4MV	18-7072	18-7201
250	1970-74	R4	4MV	18-7072	18-7201
250	1979	H4	4160	18-7017	—
260	1975-76	R4	4MV	18-7072	18-7201
260	1979-89	R4	4MV	18-7095	18-7201
290 JET	1974-75	R4	4MV	18-7072	18-7201
2.3L	1987-89	R2	2GE	18-7086	18-7200
2.5L	1982-85	R2	2GC	18-7070	18-7200
2.5L	1986-90	R2	2GE	18-7086	18-7200
2.5L	1986	R2	2GC	18-7070	18-7200
3.0L ⑥	1982-90	R2	2GC	18-7070	18-7200
3.0L/3.0L H.O.	1991-92	H-2	2300	18-7246	N/A
3.8L	1979-85	R2	2GE	18-7086	18-7200
4.3L	1986-89	R2	2GE	18-7086	18-7200
4.3L	1979-89	R4	4MV	18-7095	18-7201
4.3,4.3 H.O. ②	1990-92	H2	2300	18-7238	N/A
4.3,4.3 H.O. ③	1990-92	H4	4160	18-7237	N/A
4.3/262 ②	1989	R2	2GE	18-7086	18-7200
5.0L (GM)	1979-85	R2	2GE	18-7086	18-7200
5.0L (GM)	1979-89	R4	4MV	18-7095	18-7201
5.0L (FORD)	1989	H2	2300	18-7081	18-7206
5.0,5.0 H.O. ③	1989-90	H4	4160	18-7237	N/A
5.0,5.0 H.O. ②	1989-90	H2	2300	18-7236	N/A
5.0,5.0 H.O. ③	1991	H4	4160	18-7245	N/A
5.0,5.0 H.O. ②	1991	H4	4175	18-7244	N/A
5.0,5.0 H.O. ①	1992	H4	4150	18-7242	N/A
5.7L	1979-89	R4	4MV	18-7095	18-7201
5.7	1990-92	H4	4175	18-7239	N/A
5.7 LE ⑨	1991-92	H4	4175	18-7243	N/A
5.7 LE ④	1990	H4	4175	18-7239	N/A
5.8L	1989	H4	4160	18-7017	—
7.5L	1987-88	H4	4160	18-7017	—
305 C.I./B	1977-79	R2	2GE	18-7086	18-7200
305 C.I./B	1977-78	R4	4MV	18-7018	18-7201
305 C.I./B	1979-83	R4	4MV	18-7095	18-7201
350 C.I./B	1977-78	R4	4MV	18-7018	18-7201

② For 2V Carburetors ⑥ For 1990 PWC Suffix Only ① For Engine Model 744DPEAMH, 744DPPAMH
 ③ For 4V Carburetors ⑨ For Engine Model 574APERGD ② For Engine Model 744CPEAMH, 824BPEAM
 ④ For Engine Model 574APEPWS

CARBURETOR KIT/FLOAT APPLICATION (Cont.)

Model	Years	Mfg. Code	Carb. Model	Carb. Kit	Float
350 C.I./B	1979-83	R4	4MV	18-7095	18-7201
350 ④ ③	1988-89	R4	4MV	18-7095	18-7201
350 ②	1988	R2	2GE	18-7086	18-7200
351 CID/5.8L H.O.	—	H4	4010, R50483A, R84046A (F1JL-9510-EA)	18-7727	—
351 CID/5.8L	—	H4	4160, R9393A, R9394A, R50399A, R50399-1A	18-7729	—
351 CID/5.8L	—	H4	4160C, R80434A	18-7730	—
454 C.I./B	1977-78	R4	4MV	18-7072	18-7201
454,454 H.O. ①	1991-92	H4	4150	18-7242	N/A
454,454 H.O. ②	1990-92	H4	4150	18-7241	N/A
460 C.I.	1987-88	H4	4160	18-7017	—
460	1989-90	H4	4160	18-7235	N/A

- ② For 2V Carburetors
- ③ For 4V Carburetors
- ④ For Engine Model 574APEPWS
- ⑥ For 1990 PWC Suffix Only
- ⑨ For Engine Model 574APERGD
- ① For Engine Model 744DPEAMH, 744DPPAMH
- ② For Engine Model 744CPEAMH, 824BPEAM

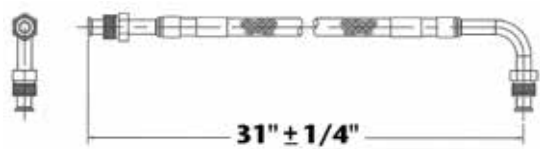



**18-8114
FUEL LINE HOSE**
For fuel pump to carburetor connection. Replaces copper or steel tubing 3/8" X 31" PTFE composite hose with 5/8"-18 male inverted flare straight one end, 5/8"-18 90° one end. SAE J1527 type A1

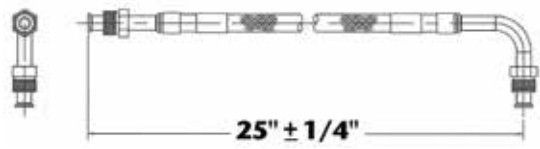



**18-8115
FUEL LINE HOSE**
For fuel pump to carburetor connection. Replaces copper or steel tubing 3/8" X 25" PTFE composite hose with 5/8"-18 male inverted flare straight one end, 5/8"-18 90° one end. SAE J1527 type A1





**18-7229
FLAME ARRESTOR**
Replaces: 986865, 981566

ALL SIERRA FUEL PUMPS INCLUDE MOUNTING GASKET



**18-7256
FUEL PUMP**
Flange I.D. # 6790
For: GM (4 & 6 cyl.)153, 230, 250, 292



**18-7258
FUEL PUMP**
Replaces: 380986
Flange I.D. # 40001, M3643
For: GM (V-6) 225, PB-V215



**18-7265
FUEL PUMP**
Flange I.D. # 41412, M73018
For: GM (V-8) 305, 350, 400



**18-7267
FUEL PUMP**
Replaces: 982063
Flange I.D. # 40778, M73016
For Ford (V-8) 302



**18-7268
FUEL PUMP**
Replaces: 981650
Flange I.D. #41415
For: GM (V-8) 305, 307, 350, 400
Dual diaphragm sight glass required.

APPLICATION BEGINS ON NEXT PAGE



18-7278
FUEL PUMP
 Replaces: 985602, 985603, 982240
Flange I.D. #M60032
 For: GM (4 & 6 cyl.) 153, 181, 250, 224, 225



18-7289
FUEL PUMP
 Replaces: 982997
Flange I.D. # 60201
 For: GM (V-6) 262/4.36



18-7326
ELECTRIC FUEL PUMP
 Replaces: 3858261, 3857986,
 3850809, 3854620



18-7330
ELECTRIC FUEL PUMP
 Replaces: 3857650, 3855958, 3854280,
 987620, 988037



18-7331
ELECTRIC FUEL PUMP
 Replaces: 3850810

FUEL PUMP APPLICATION

Model	Years	Pump #	Model	Years	Pump #
2.5	1982-85	18-7278	175	1975-77	—
5	1982-88	18-7268	185	1978-80	18-7268
5.7	1982-92	18-7268	190	1974-77	—
100	1972-73	18-7278	200	1979-81	18-7268
110	1964	18-7278	225	1978	18-7268
120	1965-80	18-7278	230	1979-81	18-7268
140	1973-81	18-7278	235	1975-77	—
140 Jet Drive	1973	18-7278	240	1978	—
150	1964	18-7258	245 Jet Drive	1973	18-7278
150 Model HU-13EM	1965	18-7258	250	1979	—
150 Except HU-13EM	1965	18-7258	260	1979-81	18-7268
165	1972-76	18-7278	305 CID IB	1979-82	18-7268
170	1974	—	350 CID IB	1979-82	18-7268
			350	1988-91	18-7268

ELECTRIC FUEL PUMP APPLICATION

Year	Engine	Application	OE #	#'s Superseded from	Part #
1992-94	262/4.3L	Low Pressure	3858261	3850809,3850810,3857985	18-7326
1997-98	350/5.7L, 454/7.4L, & 502/8.2L	Engines w/MPI - High Pressure	3857650		18-7330
1996	454/7.4L & 502/8.2L	Engines w/MPI - High Pressure	3857650		18-7330
1993-94	4.3L thru 5.8L	Low pressure electric fuel pump	3858261	3850809	18-7326
1992-1994	454/7.4L & 502/8.2L	GM Mark V Eng. - Low Pressure	3858714	3850810, 3857985	18-7331

- UNIVERSAL DESIGN -

FUEL WATER SEPARATOR BRACKETS



Bracket Type	Part #	Bracket Type	Part #
1/4" Stainless Steel	18-7777	1/4" Aluminum	18-7853-1
3/8" Stainless Steel	18-7776	3/8" Aluminum	18-7775

FUEL WATER SEPARATOR KITS



21 MICRON FILTER KITS - FOR CARBURETED ENGINES

Kit Type	Part #	Micron Rating	Contents
1/4" Aluminum (Short Filter)	18-7848-1	21	1 - 18-7844 filter & 1 18-7853-1 bracket 2 - 18-4256 1/4" pipe plugs
1/4" Aluminum Bonus Pack Contains spare filter	18-7848-2	21	2 - 18-7844 filter & 1 18-7853-1 bracket 2 - 18-4256 1/4" pipe plugs
1/4" Aluminum (Tall Filter)	18-7852-1	21	1 - 18-7845 filter & 1 18-7853-1 bracket 2 - 18-4256 1/4" pipe plugs
1/4" Aluminum Bonus Pack Contains spare filter	18-7852-2	21	2 - 18-7845 filter & 1 18-7853-1 bracket 2 - 18-4256 1/4" pipe plugs
3/8" Aluminum (Tall Filter)	18-7775-1	21	1 - 18-7845 filter & 1 18-7775 bracket 2 - 18-4264 3/8" pipe plugs
1/4" Stainless Steel (Tall Filter)	18-7777-1	21	1 - 18-7845 filter & 1 18-7777 bracket 2 - 18-4256 1/4" pipe plugs
3/8" Stainless Steel (Tall Filter)	18-7776-1	21	1 - 18-7845 filter & 1 18-7776 bracket 2 - 18-4264 3/8" pipe plugs



10 MICRON FILTER KITS FOR FUEL INJECTED ENGINES

Kit Type	Part #	Micron Rating	Contents
1/4" Aluminum (Short Filter)	18-7983-1	10	1 - 18-7944 filter & 1 18-7853-1 bracket 2 - 18-4256 1/4" pipe plugs
1/4" Aluminum Bonus Pack Contains spare filter	18-7983-2	10	2 - 18-7944 filter & 1 18-7853-1 bracket 2 - 18-4256 1/4" pipe plugs
1/4" Aluminum (Tall Filter)	18-7982-1	10	1 - 18-7945 filter & 1 18-7853-1 bracket 2 - 18-4256 1/4" pipe plugs
1/4" Aluminum Bonus Pack Contains spare filter	18-7982-2	10	2 - 18-7945 filter & 1 18-7853-1 bracket 2 - 18-4256 1/4" pipe plugs
1/4" Aluminum (High Capacity Filter)	18-7966-1	10	1 - 18-7866 filter & 1 18-7853-1 bracket 2 - 18-4256 1/4" pipe plugs
3/8" Aluminum (Tall Filter)	18-7986-1	10	1 - 18-7945 filter & 1 18-7775 bracket 2 - 18-4264 3/8" pipe plugs
1/4" Stainless Steel (Tall Filter)	18-7984-1	10	1 - 18-7945 filter & 1 18-7777 bracket 2 - 18-4256 1/4" pipe plugs
3/8" Stainless Steel (Tall Filter)	18-7985-1	10	1 - 18-7945 filter & 1 18-7776 bracket 2 - 18-4264 3/8" pipe plugs



10 MICRON FILTER KITS WITH DRAIN BOWLS

Sierra AquaVue™ and metal bowl separator filters allow water to be drained from the filter to extend service life. Use the AquaVue™ bowl for outboard, above deck installations. USCG regulations require the use of the flame resistant metal bowl below deck.

Kit Type	Part #	Micron Rating	Contents
1/4" Aluminum w/ metal drain bowl	18-7951	10	1 - 18-7919 filter & 1 18-7853-1 bracket 1 - 18-7924 metal bowl 2 - 18-4256 1/4" pipe plugs
1/4" Stainless Steel w/ metal drain bowl	18-7938	10	1 - 18-7919 filter & 1 18-7777 bracket 1 - 18-7924 metal bowl 2 - 18-4256 1/4" pipe plugs

COMPACT BRACKET AND SEPARATOR KIT - FOR SMALL OUTBOARDS AND FRESH WATER APPLICATIONS

18-7774
COMPACT ALUMINUM BRACKET



18-7965-1
10 MICRON COMPACT SEPARATOR KIT
Contains:
1 - 18-7774 bracket
1 - 18-7865 filter



REPLACEMENT FILTERS



UNIVERSAL DESIGN

10 MICRON REPLACEMENT FILTERS			21 MICRON REPLACEMENT FILTERS		
Part #	Description		Part #	Description	
18-7944	Short - 3.875"		18-7844	Short - 3.875"	
18-7945	Long - 4.35"			Long - 4.35"	
18-7866	High Capacity - 6"		18-7845	Short - 3.875"	
18-7865	Compact 10 Micron			Long - 4.35"	

REPLACEMENT FILTERS FOR OMC

10 MICRON REPLACEMENT FILTERS			21 MICRON REPLACEMENT FILTERS		
Part #	Description	Replaces	Part #	Description	Replaces
18-7946	OMC thread	OMC 502905	18-7846	OMC thread	OMC 502905
18-7989	Cobra EFI	OMC 502906	18-7789	Cobra EFI	OMC 502906



10 MICRON REPLACEMENT FILTERS AND KITS WITH DRAIN BOWLS

REPLACEMENT FILTERS			FILTER & BOWL KITS		
Part #	Description	Replaces	Part #	Description	
18-7919	Spin on replacement	Racor S3213	18-7929	Filter & Metal Bowl Contains: 18-7919 filter, 18-7924 bowl	
18-7920	Spin on replacement	OMC 771839 Racor S3214		18-7941	Filter & AquaVue™ Bowl OMC style Contains: 18-7920 filter, 18-7922 bowl
18-7947	Spin on replacement Fits - 120RRAC01	Racor S3240	18-7943		Filter & Metal Bowl OMC style Contains: 18-7920 filter, 18-7924 bowl
18-7948	Spin on replacement Fits - 320RRAC01	Racor S3227			
18-7949	Spin on replacement Fits - 660RRAC02	Racor S3232			
REPLACEMENT BOWLS			REPLACEMENT ELEMENTS		
Part #	Description		Part #	Description	Replaces
18-7924	Metal Collection Bowl		18-7930	1977-83 Fuel system with add on filter kit	OMC 173326



18-7792
FUEL FILTER
Replaces: 910641, 3855104
Fits: OMC 3.0L (1996-98), 3.8L/170 (1981)



18-7854
FUEL FILTER
Replaces: 984491, 311684
Rochester 17078904



18-7855
FUEL FILTER
Replaces: 983870, 910139
Rochester 17068453



**18-7717
FILTER ELEMENT**
For: Rochester 2 bbl & 4 bbl Carburetors



**18-7859
FUEL FILTER**
Replaces: 908034
For: Most GM Inline 4 & 6 cycle:
Ford and GM V-8's up to 400 HP



**18-7860
FUEL FILTER**
Replaces:
381690, 312456
with AC Fuel Pumps
For: Inline 4 & 6 cycle engines



**18-7861
REPLACEMENT
CANISTER AND FILTER**
Replaces: 981911



**18-7862
FUEL FILTER ELEMENT**
For Fuel Filter
(Includes Gasket)
Replaces: 982230



**18-7964
TRANSMISSION FILTER KIT**



**18-8072
FUEL ELBOW**
3/8" Hose Barb with
3/8" NPT Thread
Replaces: 174177
90

Display Package



**HOSE BARB
NPT Thread**
18-8074 3/8" with 1/4"
18-8055 5/16" with 1/4"
Replaces: 173312 Replaces: 173311

Display Package

PKG OF 10

SNAPPER CLAMPS

Part #	Clamp O.E. #	Clamp Range	Size
18-8020 ①	322652	.538 - .608	8
18-8021 ①	911616	.597 - .665	10
18-8034 ①	329654	.670 - .780	12
18-8200 ①	322653	.360 - .406	2
18-8201 ①	124249	.410 - .468	4
18-8202 ①	322654	.475 - .536	6
18-8203 ①	329653	.750 - .875	14
18-8204 ①	324825	.875 - .975	19

ALL SIERRA WATER PUMPS ARE BI-DIRECTIONAL



**18-3574
CIRCULATING WATER PUMP**
Big block GM engines with composite timing covers "Late Model" includes 482 and 502 CID
Replaces: 3855991



**18-3575
CIRCULATING WATER PUMP**
Replaces: 984360, 986779, 380640, 3854017



**18-3577
CIRCULATING WATER PUMP**
Replaces: GM 6269358, OMC 987447, 983296, 986074, 3854118



**18-3578
CIRCULATING WATER PUMP**
Replaces: 984876



**18-3583
CIRCULATING WATER PUMP**
Replaces: 985429, 980477, 382218, 3853850



**18-3584
CIRCULATING WATER PUMP**
Replaces: 982517, 3853796, 982515

① This product is priced per piece. To order priced per package, please add -9 to the part number.

WATER CIRCULATING PUMP APPLICATION

Model	Year	Part #	Model	Year	Part #	Model	Year	Part #
2.3	1987-90	18-3578	165	1972-76	18-3575	245	1972-75	18-3583
2.5	1982-86	18-3575	175	1977	18-3584	245		
3	1982-92	18-3575	185	1967-80	18-3583	Jet Drive	1972-75	18-3583
3.8	1981-86	18-3583	190	1977	18-3584	250		
4.3	1985-92	18-3583	200	1979-81	18-3583	Inboard	1970-74	18-3583
5	1982-88	18-3583	210	1968-70	18-3583	250	1979	18-3575
5	1989-92	18-3575	210			260		
5.7	1982-92	18-3583	Inboard	1970-72	18-3583	Inboard	1975-76	18-3583
5.8	1989-92	18-3575	215	1971	18-3583	260	1979-81	18-3583
100	1972	18-3575	225	1972-78	18-3583	262	1989	18-3583
100	1973	18-3583	225			290		
120	1965-69	18-3575	Inboard	1973-74	18-3583	Jet Drive	1974-75	18-3583
120	1972	18-3575	230			305 CID IB	1977-82	18-3583
120	1973-74	18-3583	Inboard	1975-76	18-3583	350 CID IB	1977-82	18-3583
120	1975-81	18-3575	230	1979-81	18-3583	350	1988-92	18-3583
140			235	1971	18-3583	351	1992	18-3584
Jet Drive	1973	18-3575	235	1977	18-3584	454 CID IB	1977-80	18-3577
140	1973-81	18-3575	240	1978	18-3584	454 CID IB	1982	18-3583



**18-3005
IMPELLER**
Replaces: 377992



**18-3058
IMPELLER**
Replaces: 983895



**18-3086
IMPELLER**
Replaces: 379475, 777130

IMPELLER APPLICATION

Model	Years	Impeller	Model	Years	Impeller
2.3	1987-90	18-3058 ③	175	1975-77	18-3086
2.5	1986	18-3058	185	1967-68, 1978-84	18-3086
3	1986-92	18-3058 ③	190	1974-77	18-3086
4.3	1986-92	18-3058	200	1966-68, 1979-84	18-3086
5	1986-92	18-3058	210	1968-72	18-3086
5.7	1986-92	18-3058 ④	215	1971	18-3086
5.8	1989-92	18-3058	225	1972-76, 1978	18-3086
7.5	1987	18-3058	230	1975-76, 1979-81	18-3086
80	1968-69	18-3005	235	1971, 1975-77	18-3086
88	1964	18-3005	240	1978	18-3086
90	1965-68, 1970-71	18-3005	245	1972-75	18-3086
100	1972-73	18-3086	250	1970-74, 1979	18-3086
110	1964	18-3005 ①	260	1975-76, 1979-84	18-3086
110	1964	18-3086 ②	262	1989	18-3058
120	1965-67	18-3005 ①	305	1977-78	18-3086
120	1965-67	18-3086 ②	350	1977-78	18-3086
120	1968-84	18-3086	350	1988-91	18-3058
140	1973-84	18-3086	370	1988	18-3058
150	1964-66	18-3086	454	1977	18-3086
155	1967-72	18-3086	454	1990-91	18-3058
165	1972-76	18-3086	460	1988-90	18-3058
170	1974	18-3086			

- ① Standard pump
- ② Heavy duty pump

- ③ Except models originally equipped with short impeller or retrofitted with short impeller kit
- ④ Except 1992 5.7 L.E. models



**18-3108
IMPELLER KEY**
Replaces: 308928
Fits: Stern Drive models (1968-85)
For: Stringer Drive Impellers 18-3005 & 18-3086



**18-3111
WATER PUMP
SHAFT SEAL**
Replaces: 907774
I/O 1972-86
EXCEPT COBRA



**18-4833
WATER PASSAGE
HOUSING
(LOWER UNIT)**
Replaces: 915720
Fits: OMC Cobra (1986-93) without cone clutch



**18-4837
WATER PASSAGE COVER**
Replaces: 911734
Fits: OMC Cobra (1986-93) without cone clutch



**18-3119
WATER PUMP HOUSING**
Replaces: 983298



**18-3206
WATER PUMP HOUSING**
Replaces: 984744
For: OMC Cobra



**18-3145
PUMP LINER**
Replaces: 911844



**18-3121
IMPELLER PLATE**
Replaces: 911703
COBRA



**18-3141
IMPELLER PLATE**
Replaces: 313176
110-260 HP I/O 1968-86
EXCEPT COBRA



**18-3502
WATER PUMP VENT HOSE**
Replaces: 912614
Fits: OMC Cobra (1986-93) without cone clutch

① **18-3212-1D** Display Package



**18-3212-1
IMPELLER
REPAIR KIT**
Replaces: 984461

— CONTAINS —

Part #	Description	O.E.M. #	Qty.
18-2541	O-Ring	911704	1
18-2916	Water Pump Housing Gasket	911702	1
18-3058	Impeller	983895	1
18-3121	Impeller Plate	911703	1
18-3145	Pump Liner	911844	1



**18-3286
IMPELLER
REPAIR KIT**
1964-86
EXCEPT COBRA

— CONTAINS —

Part #	Description	O.E.M. #	Qty.
18-7135	O-Ring	310584	1
18-3141	Plate	313176	1
18-7129	O-Ring	314491	1
18-3111	Rubber Seal	907774	1
18-3086	Impeller	379475	1
18-7158	O-Ring	310585, 310967	1



**18-3386
WATER PUMP KIT**
Replaces: 983218
1964-86
EXCEPT COBRA

— CONTAINS —

Part #	Description	O.E.M. #	Qty.
18-7135	O-Ring	310584	1
18-3141	Plate	313176	1
18-7129	O-Ring	314491	1
18-3086	Impeller	379475	1
18-3111	Rubber Seal	907774	1
18-3119	Impeller Housing	983298	1
18-7158	O-Ring	310585, 310967	1



**18-3348
COMPLETE WATER PUMP KIT**
Replaces: 984461
For: All OMC Cobra Drives-2.3 (1987-90), 2.5 (1986), 3.0(1986-93), 4.3(1986-93), 4.6(1989), 5.0(1986-93), 5.7(1986-93), 5.8 (1989-93), 7.5(1987-89)



**18-3349
WATER PUMP HOUSING KIT**
For: All OMC Cobra Drives-2.3 (1987-90), 2.5 (1986), 3.0(1986-93), 4.3(1986-93), 4.6(1989), 5.0(1986-93), 5.7(1986-93), 5.8 (1989-93), 7.5(1987-89)



**18-5897
SENDER**
Replaces: 980613
3/8" — 18 NPT
For: Mercruiser Vazer



**18-5898
SENDER**
Replaces: 171960
1/2" — 14 NPT



**18-5899
OIL PRESSURE
SENDER**
Replaces: 982650



**18-3554
THERMOSTAT**
Replaces: 383307
160°



**18-3558
THERMOSTAT**
Replaces: 982554, 3853799
160°

① **18-3653D** Display Package



**18-3653
THERMOSTAT KIT**

— CONTAINS —

Part #	O.E. #	Desc.
18-3554	383307	Thermostat
18-2858	314809	Manifold Gasket
18-2917	3701777 (GM)	Thermostat Gasket
18-2947	310913	Thermostat Gasket

APPLICATION FOR THERMOSTATS/KITS ON NEXT PAGE

① Items ending in "D" are Display Packaged - Regular number is Non-Display



① 18-3670D Display Package

18-3670 THERMOSTAT KIT
Fits: 2.5L & 3.0L (1982-88)

— CONTAINS —

Part #	O.E.#	Desc.
18-3558	982554	Thermostat
18-2858	314809	Thermostat Housing Cover Gasket
18-0929	313416	Thermostat Gasket



① 18-3676D Display Package

18-3676 THERMOSTAT KIT
140°

For: 7.4L (1994-98), 8.2L (1998)

— CONTAINS —

Part #	O.E.#	Desc.
18-7170	3852071	O-Ring
18-2917	3852111	Thermostat Gasket
—	3853983	Thermostat



① 18-3677D Display Package

18-3677 THERMOSTAT KIT
160°

— CONTAINS —

Part #	O.E.#	Desc.
18-7170	3852071	O-Ring
18-2917	3852111	Thermostat Gasket
—	3856961	Thermostat

HP	Year	HP	Year
4.3L	1994-97	5.8L	1994-97
4.3 HO	1991-97	5.8 (EFI)	1993-97
5.0 L	1994-97		

THERMOSTAT AND THERMOSTAT KIT APPLICATION

Model	Years	Thermostat	Thermostat Kit	Model	Years	Thermostat	Thermostat Kit
90	1970	18-3554	18-3653	250	1970-73	18-3554	18-3653
100	1972-73	18-3554	18-3653	250	1979	18-3554	18-3653
120	1969-80	18-3554	18-3653 ①	260	1979-81	18-3554	18-3653
120	1980-81	18-3558	18-3670 ②	262	1989	18-3554	—
140	1973-80	18-3554	18-3653 ①	305	1977-82	18-3554	18-3653
140	1980-81	18-3558	18-3670 ②	350	1977-82	18-3554	18-3653
155	1969-72	18-3554	18-3653	350	1989	18-3554	—
165	1972-76	18-3554	18-3653	351	1992	18-3554	—
170	1974	18-3554	18-3653	454	1977-82	18-3554	18-3653
175	1975-77	18-3554	18-3653	460	1989	18-3554	—
185	1978-80	18-3554	18-3653	2.5L	1982-88	18-3558	18-3670
190	1974-77	18-3554	18-3653	3.0L	1982-88	18-3558	18-3670
200	1979-81	18-3554	18-3653	3.8L	1981-85	18-3554	18-3653
210	1969-72	18-3554	18-3653	4.3L	1985-86	18-3554	18-3653
215	1971	18-3554	18-3653	4.3L	1989-92	18-3554	—
225	1971	18-3554	18-3653	5.0L	1982-88	18-3554	18-3653
230	1979-81	18-3554	18-3653	5.0L	1989-92	18-3554	—
235	1971	18-3554	18-3653	5.7L	1982-88	18-3554	18-3653
235	1975-77	18-3554	18-3653	5.7L	1989	18-3554	—
240	1978	18-3554	18-3653	5.8L	1989-92	18-3554	—
245	1972-75	18-3554	18-3653	7.5L	1988	18-3554	18-3653

① 1980 Models with "C" suffix only ② 1980 Models with "C1" suffix only

SINGLE DIAMETER HOSE



18-70021 MOLDED HOSE
3/4" ID



18-70704 MOLDED HOSE
1 1/4" ID

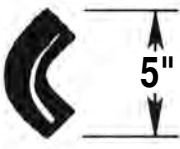

18-70924 MOLDED HOSE
1 3/4" ID



18-71218 MOLDED HOSE
1" ID



18-71337 MOLDED HOSE
1 3/4" ID

STRAIGHT HOSE



18-75100 MOLDED HOSE
Straight 48"
1" ID



18-75125 MOLDED HOSE
Straight 48"
1 1/4" ID

① Items ending in "D" are Display Packaged - Regular number is Non-Display

V-BELTS

- 1 High strength synthetic cords resist shockload failure. Their low stretch properties assure uniform performance over the life of the belt.
- 2 The compression section is a special rubber compound that assures smooth and even transfer of load forces to the cords.
- 3 Cogs are molded to precise engineering tolerances to improve flexibility and maintain cord support. Cog geometry provides a large area for air circulation to keep the belt cool and prevent damaging heat build up in the cushion section.
- 4 Rubber edges maintain positive, no-slip contact with pulley grooves for reliable energy transfer.

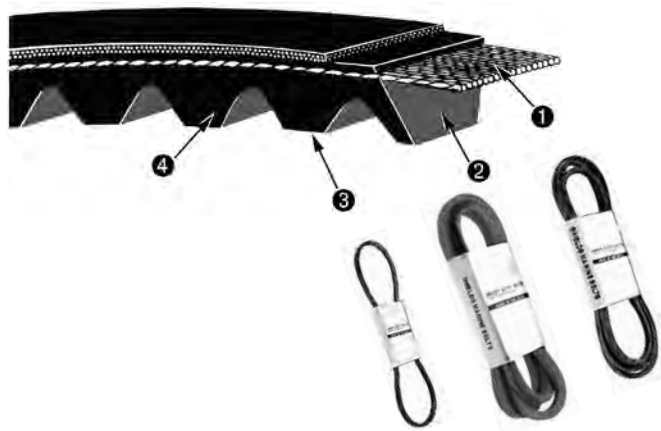

BELT SIZE LISTING BY NUMBER

Part #	Effective Length (Inches)	Top Width (Inches)	Part #	Effective Length (Inches)	Top Width (Inches)	Part #	Effective Length (Inches)	Top Width (Inches)
18-15290	29	29/64	18-15405	40 1/2	29/64	18-15460	46	29/64
18-15300	30	29/64	18-15410	41	29/64	18-15470	47	29/64
18-15325	32 1/2	29/64	18-15415	41 1/2	29/64	18-15480	48	29/64
18-15345	34 1/2	29/64	18-15430	43	29/64	18-15495	49 1/2	29/64
18-15370	37	29/64	18-15435	43 1/2	29/64	18-15500	50	29/64
18-15380	38	29/64	18-15440	44	29/64	18-15520	52	29/64
18-15390	39	29/64	18-15450	45	29/64	18-15550	55	29/64
18-15400	40	29/64	18-15455	45 1/2	29/64			

V-BELT INTERCHANGE

OMC #	Part #	Part #	OMC #
310953	18-15460	18-15380	910414
311046	18-15440	18-15400	311606
311606	18-15400	18-15415	910343
908929	18-15455	18-15435	912509
909818	18-15500	18-15440	311046
909971	18-15460	18-15450	914787
910343	18-15415	18-15455	908929
910414	18-15380	18-15460	310953
912418	18-15500	18-15460	909971
912509	18-15435	18-15500	909818
912714	18-15520	18-15500	912418
914787	18-15450	18-15520	912714

HOSE INTERCHANGE

OMC #	Part #	Sierra #	Part #
312781	18-71337	18-71337	312781
910305	18-75100	18-75100	910305
912424	18-75100	18-75100	912424
912793	18-75125	18-75100	913488
913488	18-75100	18-75125	912793

V-BELT APPLICATION

Model	Year	Water Alternator	Pump	Power Steering	Model	Year	Water Alternator	Pump	Power Steering
100	1972-73	18-15400	18-15400	—	262 KING COBRA	1989	—	*18-15380	18-15455
110	ALL	18-15440	18-15440	—	305	1977-84	18-15440	18-15440/ *18-15455 or *18-15500	—
120	1965-81	18-15400	18-15400	—	350	1977-84	18-15440	18-15440/ *18-15455 or *18-15500	—
140	1982-87	18-15400	18-15400	—	350 KING COBRA	1988-90	18-15455	18-15455	—
165	1972-76	18-15400	18-15400	—	350 KING COBRA	1988-90	18-15470	*18-15380	18-15455
170	1974	18-15400	18-15400	—	454	1977-82	18-15455	18-15455/ *18-15500	—
175	1975-77	18-15400	18-15400	—	454 KING COBRA	—	—	18-15470	18-15380
185 W/O PS	1978-84	18-15440	18-15440	—	460 KING COBRA	1988	18-15460	18-15460	18-15520
185 W/ PS	1978-84	18-15460	18-15460	18-15460	888	—	18-15435	18-15435	—
190	1974-77	18-15400	18-15400	—	2.3L	1987-90	18-15435	18-15435	18-15435
200 W/O PS	1979-81	18-15440	18-15440	—	2.5L W/O PS	1982-87	18-15415	18-15415	—
200 W/ PS	1979-81	18-15460	18-15460	18-15460	2.5L W/ PS	1982-87	18-15400	18-15400	18-15460
210	1970-71	18-15440	18-15440	—	3.8L W/O PS	1982-90	18-15400	18-15400	—
215	1971	18-15440	18-15440	—	3.8L W/ PS	1982-90	—	*18-15380	18-15455
225	1972-84	18-15440	18-15440	—	5.0L W/O PS	1982-90	18-15455	18-15455	—
230,260	1975	18-15440	18-15440/ *18-15455	—	5.0L W/ PS	1982-90	—	*18-15380	18-15455
230,260	1979-81	18-15440	18-15440	—	7.5L	1987	18-15460	18-15460	18-15520
230,260	1979-81	18-15460	18-15460	18-15460					
235	1971	18-15440	18-15440	—					
235	1975-77	18-15400	18-15400	—					
240	1978-84	18-15400	18-15400	—					
250	1979	18-15400	18-15400	—					
262 KING COBRA	1989	18-15400	18-15400	—					

* W/ SEA WATER PUMP

Fits GM 181 CID 3.0L, 4 Cylinder Fits Most 141 Models

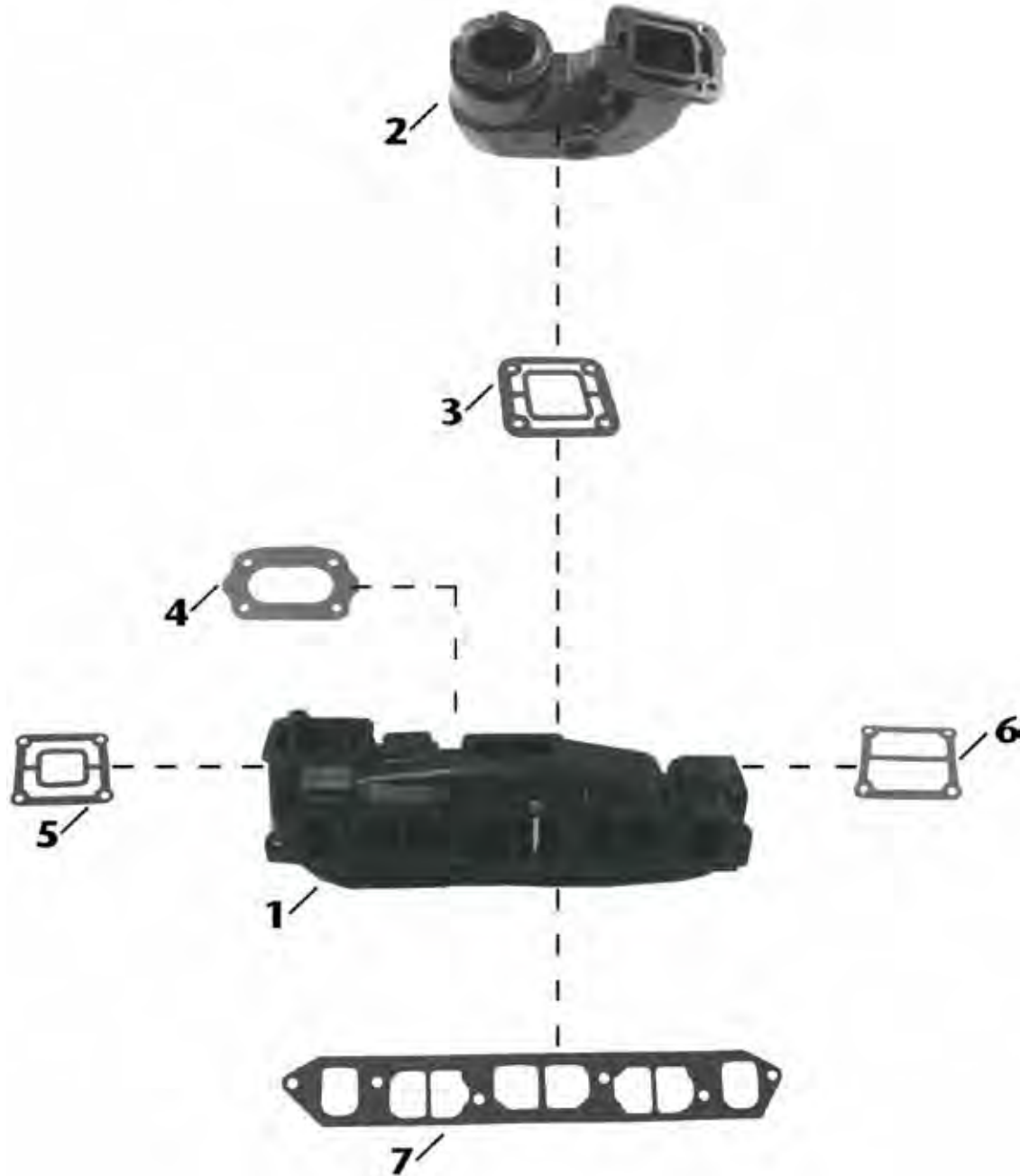

Item No	Description	OE No.	Application
1	18-1901 MANIFOLD	982490, 980083, 984054	GM 181 cu.in. 3.0L , 4 Cylinder. Fits most 140 models.
2	18-1922 MANIFOLD ELBOW	987784	Use with Manifold: 18-1901; Elbow Gasket: 18-2875
3	18-2875 ELBOW GASKET	385049	Use with Elbow: 18-2875
4	18-0937 CARBURETOR GASKET	315055	Use with Manifold: 18-1901
5	18-2861 END PLATE GASKET	311121	Use with Manifold: 18-1901
6	18-0114 END PLATE GASKET	907761	Use with Manifold: 18-1901
7	18-1204 MANIFOLD GASKET	912164	Use with Manifold: 18-1901

Fits GM Small Block V8 305-350 cu. in. 1979-1989

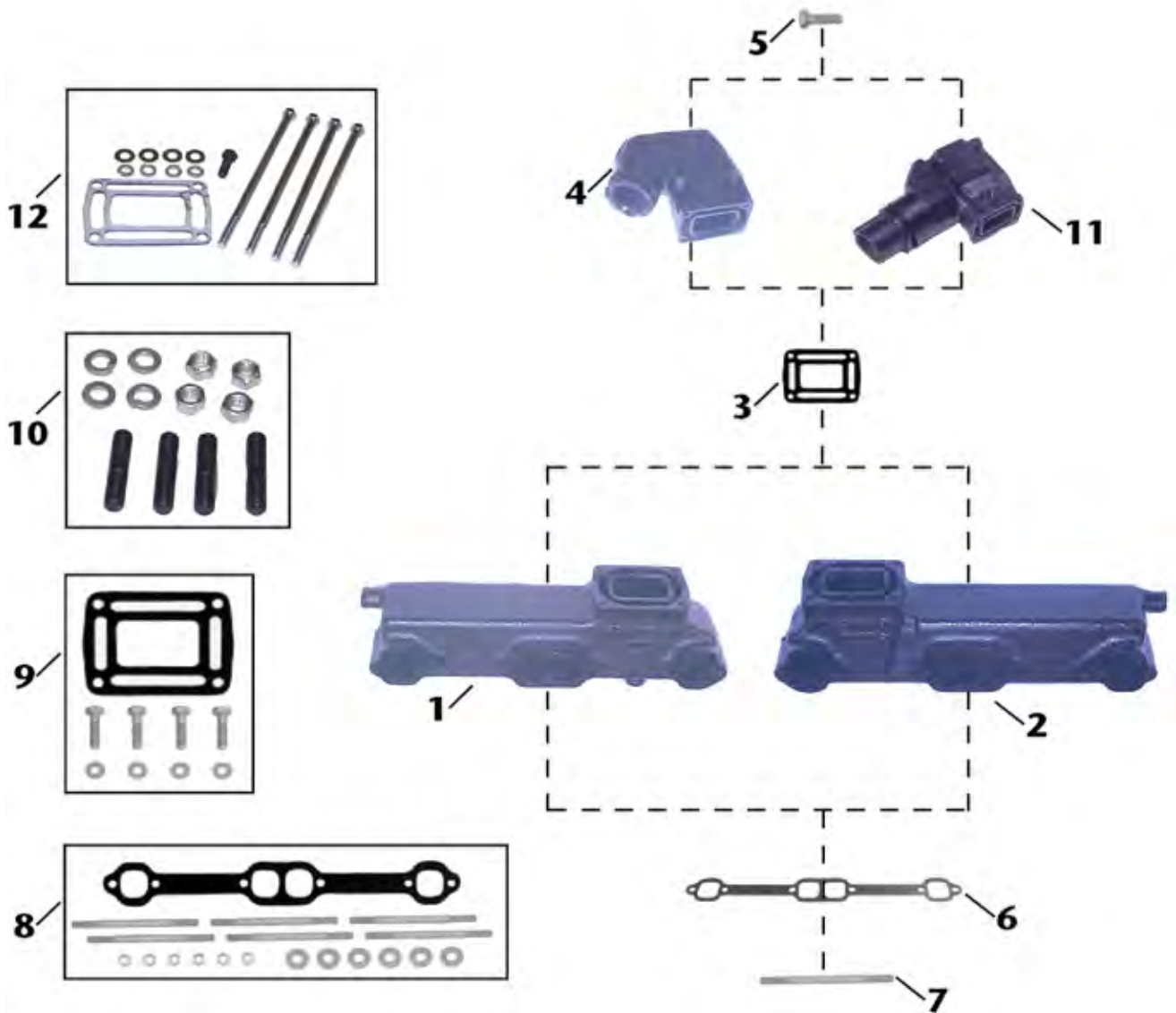

Item No	Description	OE No.	Application
1	18-1902	MANIFOLD (STARBOARD) 912441	GM Small Block (V8) 305-350 cu.in. (1979-1989)(Starboard) Use with Manifold Gasket: 18-2949. Mounting Kit: 18-8502
2	18-1903	MANIFOLD (PORT) 912442	GM Small Block (V8) 305-350 cu.in. (1979-1989)(Port). Use with Manifold Gasket: 18-2949. Mounting Kit: 18-8502
3	—	ELBOW GASKET 909786	Use with Elbow: 18-1921; Mounting Kit: 18-8534.
4	18-1921	MANIFOLD ELBOW 909863	Use with Manifold: 18-1902, 18-1903. Mounting Kit: 18-8534.
5	NSS	MOUNTING BOLT N/A	Included in 18-8534 mounting kit.
6	18-2949	MANIFOLD GASKET 96306	Use with Manifold: 18-1902, 18-1903. Included in 18-8502 mounting kit.
7	NSS	MOUNTING STUD N/A	Included in 18-8502 mounting kit.
8	18-8502	MOUNTING KIT N/A	Use with Manifold: 18-1902, 18-1903. Includes 18-2949 manifold gasket.
9	18-8534	MOUNTING KIT N/A	Use with Elbow: 18-1921.
10	18-8553	HARDWARE KIT N/A	Hardware only for Elbow 18-1921.
11	18-1909-1	MANIFOLD ELBOW N/A	Use with Elbow Gasket: 18-0943-1
12	18-8507	MOUNTING KIT N/A	Use with Manifold Elbow: 18-1909-1

Fits GM Small Block V8 305-350 cu. in.

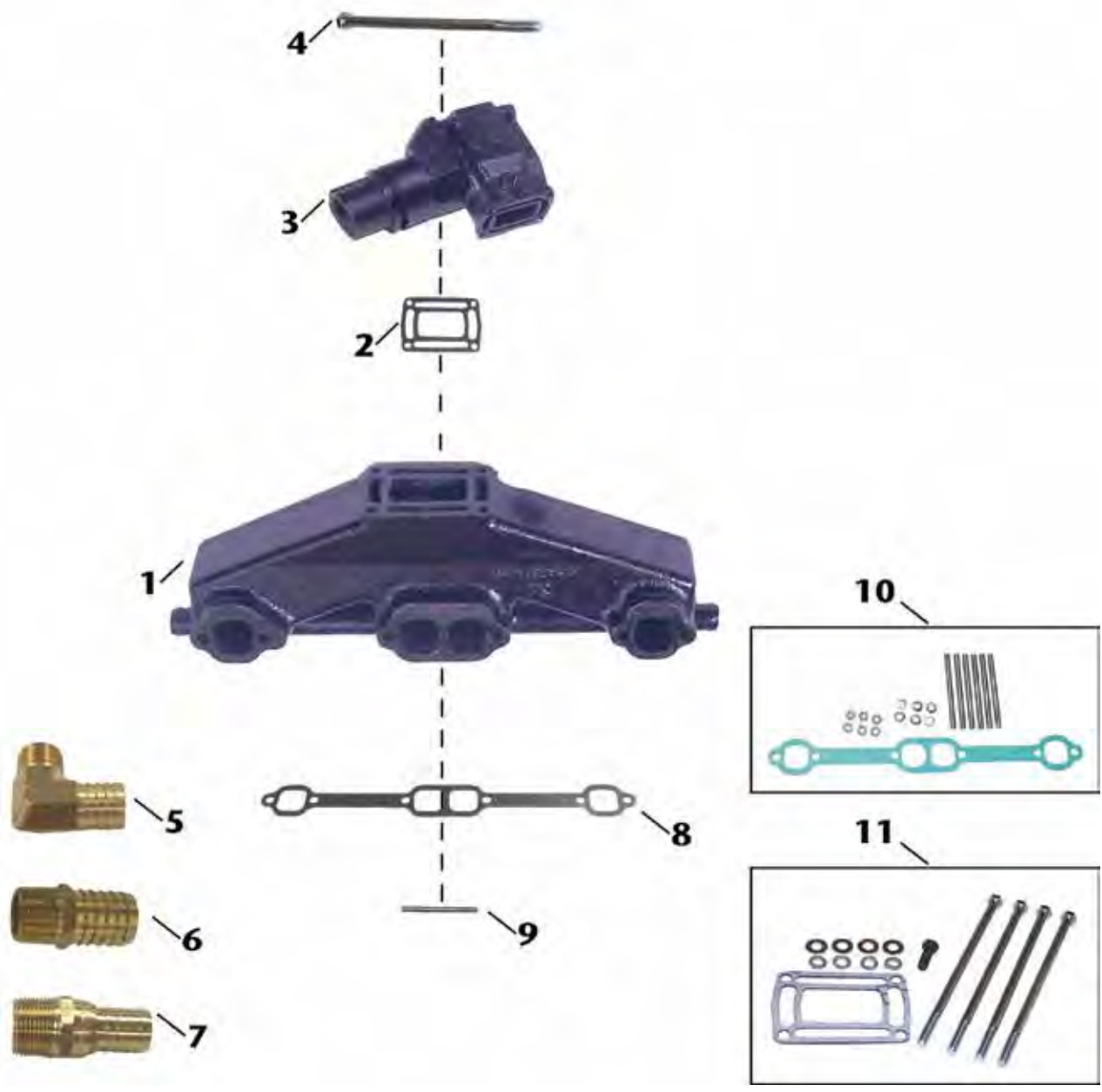

Item No	Description	OE No.	Application
1	18-1986-1 MANIFOLD	3857723	GM Small Block (V8) 305-350 cu.in. Use with Manifold Gasket: 18-2949; Mounting Kit: 18-8502.
2	— ELBOW GASKET	909786	Use with Elbow: 18-1909-1. Included in 18-8507 mounting kit.
3	18-1909-1 MANIFOLD ELBOW	913784, 3855270, 3850459, 3857944	Use with Manifold: 18-1986-1; Mounting Kit: 18-8507.
4	NSS MOUNTING BOLT	N/A	Included in 18-8507 mounting kit.
5	18-8216 HOSE FITTING	N/A	3/4" - 14NPT X 1" Hose (Corrosion Resistant Brass Fitting)
6	18-4461 HOSE FITTING	N/A	3/4" - 14NPT X 1" Hose (Corrosion Resistant Brass Fitting)
7	18-8215 HOSE FITTING	N/A	3/4" - 14NPT X 3/4" Hose (Corrosion Resistant Brass Fitting)
8	18-2949 MANIFOLD GASKET	96306	Use with Manifold: 18-1986-1. Included in 18-8502
9	NSS MOUNTING STUD	N/A	Included in 18-8502 mounting kit.
10	18-8502 MOUNTING KIT	N/A	Use with Manifold 18-1986-1. Includes 18-2949 manifold gasket.
11	18-8507 MOUNTING KIT	N/A	Use with Elbow: 18-1909-1. Includes 18-0943-1 elbow gasket.

SIERRA MANIFOLDS ARE PAINTED, PACKAGED AND LEAK TESTED



**18-1901
MANIFOLD**
Replaces: 984054
Fits 181 CID model 140
and 3.0L (1973 - 1989)
Use with:
Exhaust Elbow Gasket: 18-1204
***For Exploded View - See PAGE 772**



**18-1898
MANIFOLD**
Port & Starboard
Replaces: Barr CHVA-1-84, Marine Power 0991-110
Fits 454 cu.in. GM big block V8 engines
Use with:
Exhaust Manifold Gasket: 18-0418
***For Exploded View - See Pages 556-557**



**18-1997-1
EXHAUST MANIFOLD**
Port & Starboard
Replaces Barr CHV-1-83 Universal Center Riser Manifold
FITS: GM 283, 305, 307 and 350 CID engines
Use with:
Exhaust Manifold Gasket Set: 18-0604
***For Exploded View - See Pages 558-559**



**18-1998-1
EXHAUST MANIFOLD**
Port & Starboard
Replaces: Barr FM-1-83
Universal Center Riser Manifold
FITS: Ford 302 and 351 CID engines
Use with:
Exhaust Manifold Gasket Set: 18-0603
***For Exploded View - See Pages 560-561**



**18-1986-1
MANIFOLD**
Port & Starboard
Replaces: 3852374, 3857723
For: GM Small Block V8 305-350 ci
Use with:
Exhaust Manifold Gasket: 18-2949
Mounting Kit: 18-8502



**18-1902
MANIFOLD**
Replaces: 912441
V-8 - STARBOARD SIDE
Fits most GM V-8 small blocks with end riser
Use with:
Mounting Kit: 18-8502



**18-1903
MANIFOLD**
Replaces: 912442 V-8 - PORT SIDE
Fits most GM V-8 small blocks with end riser
Use with:
Mounting Kit: 18-8502



**18-1904
MANIFOLD**
Port & Starboard
Replaces: 980959 V-8 - EITHER SIDE
Fits most Ford V-8 302 & 351W with end riser
Use with:
Exhaust Manifold Gasket: 18-0183 or 18-2896
(See Application Chart)



**18-1876
RISER**

Replaces: 980617
Use with:
Manifold: 18-1904
Riser Gasket: 18-2850
Fits: 170 (1974), 175 (1975-76),
190 (1974-76), 235 (1975-76)



**18-1991
30° EXHAUST ELBOW ADAPTER**

For use with 3" I.D.
Exhaust Hose
Use with:
Manifold Riser: 18-1999



**18-1992-1
80° EXHAUST ELBOW**

For 3" I.D. Exhaust Hose
(As used in 18-1987 Exhaust
Manifold Conversion Kit)

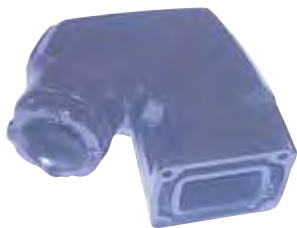

**18-1921
ELBOW MANIFOLD**

Replaces: 909863
V-8
Fits most GM V-8 small blocks
Use with:
Manifold: 18-1902, 18-1903
Elbow Gasket: 18-0943-1
Mounting Kit: 18-8534



**18-1922
ELBOW MANIFOLD**

Replaces: 987784
4 CYL.
Fits most 140 HP 3.0L (181 CID)
Use with:
Manifold: 18-1901
Elbow Gasket: 18-2875



**18-1909-1
RISER**

Replaces:
OMC 913784, 3855270, 3850456, 3857944,
VOLVO 3855270-9, 3857944-7, 3863061
OMC Riser, 4" outlet 7°: Fits many GM & Ford center rise
manifolds.
Use with:
Manifold: 18-1986-1
Riser Gasket: 18-0943-1
Mounting Kit: 18-8507



**18-1939
RISER**

Replaces: Barr 20-0100, Marine Power 0992-593 Barr, Indmar
and Marine Power Ford Small Block V8 302-351cu.in., GM Small
Block V8 305-350cu.in., GM Big Block V8 454cu.in.
Use with:
Manifold: 18-1997-1, 18-1998-1
Riser Gasket: 18-2854 open or 18-0476 blocked
Mounting Kit: 18-4364 open or 18-8535 blocked



**18-1907
RISER**

Replaces: Barr 20-0102, Indmar 53-2009,
53-2018, Barr and Indmar Ford Small Block
V8 302-351cu.in.
Use with:
Manifold: 18-1997-1, 18-1998-1
Riser Gasket: 18-2854 open or
18-0476 blocked
Mounting Kit: 18-4364 open or 18-8535
blocked



**18-1999
EXHAUST
MANIFOLD
RISER**

Replaces: Barr 20-0082
Use with:
Manifold: 18-1997-1 or 18-1998-1
Riser Gasket: 18-2854 open
Comes with 18-4364 open
If blocked mounting kit is required use 18-8535
Replaces: Barr 20-0082-P



**18-4009
MANIFOLD END PLATE**

Replaces: 910384



PIPE PLUGS

Part #	Thread Size
18-4256	1/4"
18-4257	1/4"
18-4258	3/4"
18-4263	1/8" - 27 NPT
18-4264	3/8" - 18 NPT

56507 Pipe Sealant with Teflon®
is recommended for use on plug threads.



**18-4461
HOSE BARB**

3/4" - 14 NPT X 1" Hose
Corrosion Resistant Brass Fitting



**18-8216
HOSE BARB**

Fits: OMC - In-Line 6 Cylinders

① **18-4218D**



**18-4218
BRASS DRAIN COCK**

Replaces: 379957
1/4"
18-3223-9 Bulk Pack of 12



**18-4363
MOUNTING PACKAGE**
Replaces: Barr FM-1-83-P
Use with:
Manifold: 18-1998-1



**18-4364 (Open)
MOUNTING PACKAGE**
Replaces: Barr 20-0082-P
Use with:
Riser: 18-1999, 18-1939, 18-1907



**18-8502
MOUNTING KIT**
OMC GM Small Block V8 305-350cu.in.
(1979-89) OMC/Volvo GM Small Block
305-350cu.in.
Used with:
Manifolds: 18-1931-1, 18-1902 & 18-1903



**18-8507
MOUNTING KIT**
OMC/Volvo GM
Small Block V8 305-350cu.in.
Used with:
Riser: 18-1909-1



**18-8534
MOUNTING KIT**
OMC GM Small Block V8 305-350cu.in.
(1979-1989) and multiple application Ford
and GM Risers
Used with:
Riser: 18-1921



**18-8535 (Blocked)
MOUNTING KIT**
Barr, Indmar and Marine Power Ford Small
Block V8 302-351cu.in., GM Small Block V8
305-350cu.in., GM Big Block V8 454cu.in.
Used with:
Risers: 18-1939, 18-1999, and 18-1907



**18-8536
MOUNTING KIT**
Barr, Indmar and Marine Power GM
Small Block V8 305-350cu.in.
Used with:
Manifold: 18-1997-1



**18-8538
MOUNTING KIT**
Barr and Indmar Ford Small
Block V8 302-351cu.in.
Used with:
Manifold: 18-1998-1, 18-1904



**18-8553
MOUNTING KIT**
Used with:
Exhaust Elbow: 18-1921



**18-2779
EXHAUST HOSE**
Replaces: 3852696



**18-2781
EXHAUST HOSE**
Replaces: 3852742



**18-0114
MANIFOLD END GASKET**
Replaces: 907761



**18-0183
EXHAUST MANIFOLD GASKET**
Replaces: 908717, 916262,
3852455, 3853742
Use with:
Manifold: 18-1958, 18-1962, 18-1904,
18-1998-1, 18-1996, 18-1979











**18-0476 (Blocked)
RISER GASKET**
Replaces: Barr 01-0105
Indmar & Marine Power
Ford Small Block V8 302-351cu.in.
Used with:
Risers: 18-1939, 18-1999 and 18-1907



**18-0943-1
18-0943-1-9①
EXHAUST ELBOW GASKET**
Replaces: 909786, 3850496
Used with:
Riser: 18-1909-1

① Priced per Package

<p>PKG OF 2</p>  <p>18-2850 18-2850-9^① EXHAUST ELBOW GASKET Replaces: 908935</p>	<p>PKG OF 2</p>  <p>18-2854 18-2854-9^① EXHAUST RISER GASKET Replaces: Barr 01-0107 Use with: Mounting Kit: 18-8535 Risers: 18-1999, 18-1939, 18-1907</p>	<p>PKG OF 2</p>  <p>18-2861 18-2861-9^① EXHAUST ELBOW GASKET Replaces: 311121</p>
<p>PKG OF 2</p>  <p>18-2875 18-2875-9^① EXHAUST ELBOW GASKET Replaces: 3850495, 908013 Used with: Elbow: 18-1922</p>	 <p>18-2896 MANIFOLD GASKET Replaces: 311068 For GM 4 cyl. 153 cu.in. Early models 110/120 where the carb. linkage mounts to the rear of the engine Use with: Manifold: 18-1904</p>	
<p>PKG OF 2</p>  <p>18-2902 18-2902-9^① MANIFOLD GASKET Replaces: 909314 Use with: Manifold: 18-1997-1, 18-1986-1, 18-1902, 18-1903</p>	<p>PKG OF 2</p>  <p>18-2949 18-2949-9^① MANIFOLD GASKET Replaces: Barr CHV-47-000 Use with: Manifold: 18-1997-1</p>	
 <p>18-0603 EXHAUST MANIFOLD GASKET SET For: Ford 302/351 CID Eng. Use with: Manifold: 18-1998-1</p>	 <p>18-0604 EXHAUST MANIFOLD GASKET SET For: GM 305/350 CID Eng. Use with: Manifold: 18-1997-1</p>	

① Priced per Package

MANIFOLD/MANIFOLD GASKET APPLICATION

Year	Horsepower	Exhaust Manifold	Exhaust Elbow	Manifold Mount Kit	Elbow Mount Kit	Manifold Gasket	Elbow Gasket
1997-98	5.0/5.7L	18-1986-1	18-1909-1	18-8502	18-8507	18-2902	18-0943-1
1994-97	5.8L (Ford)	—	—	—	—	18-0183	18-0943-1
1994-97	7.4L (GM)	—	—	—	—	18-0418	18-0943-1
1991-93	3.0 Liter	—	18-1922	—	—	—	18-2875
1992-93	4.3/4.3 HO	—	18-1909-1	—	18-8507	—	18-0943-1
1993	5.0/5.0 HO/5.8 Liter	—	18-1909-1	—	18-8507	18-0183	18-0943-1
1993	5.0 & 5.8 EFI	—	18-1909-1	—	18-8507	18-0183 ②	18-0943-1
1993	5.0 & 5.8 EFI	—	18-1909-1	—	18-8507	—	18-0943-1
1993	5.8L (Ford)	—	18-1909-1	—	18-8507	18-0183	18-0943-1
1993	7.4L (GM), 8.2L (GM)	—	18-1909-1	—	18-8507	18-0418	18-0943-1
1993	351 King, 454/454 HO/502	—	—	—	—	—	18-0943-1
1992	5.0/5.0 HO/5.8 Liter	—	18-1909-1	—	18-8507	18-0183	18-0943-1
1992	5.8L (Ford)	—	—	—	—	18-0183	18-0943-1
1992	7.4L (GM), 8.2L (GM)	—	—	—	—	18-0418	18-0943-1
1992	351 King Cobra	—	—	—	—	18-0183	18-0943-1
1992	454/454 HO/502	—	—	—	—	—	18-0943-1
1991	4.3/4.3 HO	—	—	—	—	—	18-0943-1
1991	5.8L (Ford), 5.0/5.0 HO/5.8 Liter	—	18-1909-1	—	18-8507	18-0183	18-0943-1

② 5.0L only

APPLICATION CONTINUED ON NEXT PAGE

MANIFOLD/MANIFOLD GASKET APPLICATION

Year	Horsepower	Exhaust Manifold	Exhaust Elbow	Manifold Mount Kit	Elbow Mount Kit	Manifold Gasket	Elbow Gasket
1991	454/454 HO	—	18-1909-1	—	18-8507	—	18-0943-1
1991	7.4L (GM)	—	18-1909-1	—	18-8507	18-0418	18-0943-1
1990-91	8.2L (GM)	—	18-1909-1	—	18-8507	—	—
1982-83,1985-90	3.0 Liter	18-1901	18-1922	—	—	—	18-2875
1990	4.3 Liter	—	18-1909-1	—	18-8507	—	—
1990	5.0/5.0 HO/5.8 Liter	—	18-1921	—	—	18-0183	18-0943-1
1990	5.0/5.7L	18-1986-1	18-1909-1	18-8502	18-8507	18-2902	18-0943-1
1990	7.4L (GM)	—	—	—	—	18-0418	18-0943-1
1990	7.5L (Ford)	—	—	—	—	18-0992	18-0943-1
1990	454 King Cobra	—	—	—	—	—	18-0943-1
1987-90	460 King Cobra	—	—	—	—	—	18-0943-1
1989	5.0/5.0 HO/5.8 Liter	—	18-1921	—	18-8534	18-0183	18-0943-1
1989	5.7/350 King Cobra	—	—	—	—	18-2902	18-0943-1
1988	5.0/5.7/350 King Cobra	18-1902 #	18-1921	18-8502	18-8534	18-2902	18-0943-1
1988	5.0/5.7/350 King Cobra	18-1903 *	18-1921	18-8502	18-8534	18-2902	18-0943-1
1988	370 King Cobra	—	—	—	—	—	18-0943-1
1982-87	5.0/5.7 Liter	18-1902 #	18-1921 ①	18-8502	18-8534	18-2902	18-0943-1
1982-87	5.0/5.7 Liter	18-1903 *	18-1921	18-8502	18-8534	18-2902	18-0943-1
1982-86	2.5 Liter	18-1901	18-1922	—	—	18-2896	18-2875
1984	3.0 Liter	18-1901	18-1921	—	18-8534	—	18-2875
1978-81	400 Series, 120 HP	—	—	—	—	18-2896	18-2861
1978-81	400 Series, 140 HP	—	18-1922	—	—	—	18-2875
1981	800 Series, 200,230,260 HP	18-1902 #	18-1921	18-8502	18-8534	18-2902	18-0943-1
1981	800 Series, 200,230,260 HP	18-1903 *	18-1921	18-8502	18-8534	18-2902	18-0943-1
1980	800 Series, 185-260 HP	18-1902 #	18-1921	18-8502	18-8534	18-2902	18-0943-1
1980	800 Series, 185-260 HP	18-1903 *	18-1921	18-8502	18-8534	18-2902	18-0943-1
1979	800 Series,185-230 HP	18-1902 #	18-1921	18-8502	18-8534	18-2902	18-0943-1
1979	800 Series,185-230 HP	18-1903 *	18-1921	18-8502	18-8534	18-2902	18-0943-1
1979	800 Series, 260 HP	18-1902 #	18-1921	18-8502	18-8534	18-2902	18-0943-1
1979	800 Series, 260 HP	18-1903 *	18-1921	18-8502	18-8534	18-2902	18-0943-1
1978	800 Series, 185-225 HP	18-1902 #	18-1921	18-8502	18-8534	18-2902	18-0943-1
1978	800 Series, 185-225 HP	18-1903 *	18-1921	18-8502	18-8534	18-2902	18-0943-1
1978	800 Series, 240 HP	—	18-1921	—	18-8534	—	—
1977	120 HP	—	—	—	—	18-2896	18-0943-1
1977	140 HP	—	18-1922	—	—	—	18-2861
1977	175 THRU 235 HP	—	18-1921	—	18-8534	18-0183	18-2875
1976	120 HP	18-1904	—	—	—	18-0183	18-0943-1
1974-76	140 HP	18-1904	18-1922	—	—	—	18-2861
1976	165 HP	18-1904	18-1922	—	—	18-2830	18-2875
1976	175 THRU 235 HP	18-1904	—	—	—	18-0183	18-2875
1974-75	120 HP	18-1904	—	—	—	18-2896	18-2850
1974-75	165 HP	18-1904	18-1922	—	—	—	18-2875
1975	175 THRU 235 HP	18-1904	—	—	—	18-0183	18-2875
1974	170 & 190 HP	18-1904	—	—	—	18-0183	18-2875
1974	175 THRU 235 HP	18-1904	—	—	—	18-0183	18-2850
1973	100,120,140 HP	—	—	—	—	18-2896	18-2861
1973	165 HP	—	18-1922	—	—	18-2896	18-2861
1972-73	225 & 245 HP	—	—	—	—	—	18-2883
1972	100,120 HP	—	—	—	—	18-2896	18-2861
1972	155 HP	—	—	—	—	N/A	18-2883
1972	165 HP S MODEL, C MODEL	—	—	—	—	—	18-2875
1971	215 & 235 HP	—	—	—	—	—	18-2859
1965-71	120 HP	—	—	—	—	—	18-2861
1967-71	155 HP	—	—	—	—	N/A	18-2859
1968-70	210 HP	—	—	—	—	—	18-2859
1967-68	185 HP	—	—	—	—	—	18-2859
1966-68	200 HP	—	—	—	—	N/A	18-2859
1964-66	150 HP	—	—	—	—	N/A	18-2859
1964	110 HP	—	—	—	—	N/A	18-2859

Starboard

* Port

① High rise applications only for 1985

② 5.0L only

OIL FILTERS



Part #	Fits:	O.E.M. #
18-7824-1	GM Engines (Short Filter)	173232, 502902
18-7875	Ford Engines (Long Filter)	173231, 502900
18-7876	GM Engines (Long Filter)	173233, 502901
18-7878-1	M-100, M200 (Short Filter)	502904
18-7879	GM V-6 Engines	173834, 502903



SEE PAGES 152-154 FOR ADDITIONAL INFORMATION

CYLINDER HEAD ASSEMBLIES



18-4484
CYLINDER HEAD ASSEMBLY
 Replaces: 985080
 Fits: 5.7L V-8 GM (1969-86) with 12 intake manifold mounting bolts, perimeter mount valve cover



18-4485
CYLINDER HEAD ASSEMBLY
 Fits: 5.7L V-8 GM (1987-95) with press in rocker arm studs with 12 intake manifold mounting bolts- (4 inside intake manifold bolts at 23 degrees), center mount valve covers



18-4486
CYLINDER HEAD ASSEMBLY
 Fits: 5.7L V-8 GM Vortec (1996-Up) with press in rocker arm studs with 8 intake manifold mounting bolts, composite valve cover



18-4489
CYLINDER HEAD ASSEMBLY
 Fits: 2.5L/3.0L GM (1968-95)



18-4491
CYLINDER HEAD ASSEMBLY
 Replaces 4.3L Vortec V-6 (1996-Up) with screw in rocker arm studs (non-adjustable valve train), 8 intake manifold mounting bolts, center mount valve cover. NOTE: not for use with engines using factory roller rocker arms.



18-4495
CYLINDER HEAD ASSEMBLY
 Replaces: 986086,988163,3854339
 Fits: (1986& Up) 5.0L Ford with D-shape 58 cc combustion chamber



18-4501
CYLINDER HEAD
 Fits: 5.0L Vortec



18-4502
CYLINDER HEAD
High Performance
 Aluminum cylinder head sold in pairs only. This utilizes a 185cc intake runner/62cc exhaust runner and 2.02/1.60 stainless valves placed in a 72cc combustion chamber.
 Fits: 5.7, 6.2L GM small block V-8



18-1400
HYDRAULIC LIFTER
 Replaces: 3856127
 GM 4.3L/V-6 Late/5.0L/5.7L



18-1401
HYDRAULIC LIFTER
 Replaces: 3853847, 985316
 Ford 5.0L & 5.8L



18-1402
HYDRAULIC LIFTER
 Replaces: 3854033, 502036
 GM 2.5L/120
 For: OMC & Volvo 3.0L/181 CID

ALL PISTONS
ARE SUPPLIED COMPLETE WITH PISTON RINGS AND WRIST PIN.



RINGS (Cont.)

STD	REPLACES OMC / VOLVO
18-3944	370409
.020	
18-3939	3854252
18-3939	914556
.030	
18-3938	*14089026
18-3938	328516
18-3938	914557

RINGS

STD	REPLACES OMC / VOLVO
18-3937	*14089025
18-3937	328506
18-3937	3853960
18-3937	914555
18-3937	3853268
18-3937	985083, 986336
18-3940	328536

PISTONS

18-4161	3853340
	914816
18-4173	*14077948
18-4173	3911020
.020	
18-4160	3853477, 915236
.030	
18-4164	*14077949
	3911023

* OMC References GM Number

PISTON/ RING APPLICATION

Model	PISTONS			RINGS			Qty. Per Eng.
	Std.	.020	.030	Std.	.020	.030	
OMC							
GM							
2.5L/153 CID	18-4180	18-4183	-	18-3942	-	-	4
3.0L/181 CID	18-4161	18-4160	18-4191	18-3937	18-3939	18-3938	4
1-6/250 CID	-	-	-	18-3942	-	-	6
4.3L/V-6	18-4173	18-4188	18-4164	18-3937	18-3939	18-3938	6
5.0L/305 CID	-	-	18-4178	18-3944	-	-	8
5.7L/350 CID	18-4173	18-4188	18-4164	18-3937	18-3939	18-3938	8
7.4L/454 CID	18-4171	18-4189	18-4172	18-3940	18-3950	18-3941	8
FORD							
5.0L/302 CID	-	-	-	18-3937	18-3939	18-3938	8





ROD BEARINGS

Part #	Size	
18-1308	Std.	
18-1309	.010	
18-1327	Std.	
18-1329	Std.	
18-1333	.010	
18-1334	Std.	
18-1337	.010	
18-1341	.020	

Rod bearings sold individually,
1 per rod



MAIN BEARINGS

Part #	Per Eng.	Size		Part #	Per Eng.	Size	
18-1300	①	Std.		18-1316	①	.010	
18-1311	①	Std.		18-1317	①	Std.	
18-1315	①	Std.					

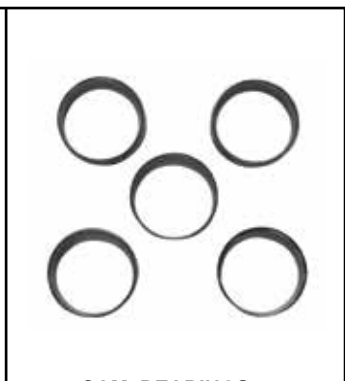

CAM BEARINGS

Part #	Per Eng.	
18-1339	1 ①	

① Complete engine set

BEARING APPLICATION

Model	ROD BEARING			MAIN BEARING			CAM BEARING
	Std.	.010	.020	Std.	.010	.020	
OMC							
GM							
2.5L/153 CID				18-1317	18-1316	-	18-1339
3.0L/181 CID	18-1308	18-1309	18-1341	18-1317	18-1316	-	18-1339
I-6/230 CID	18-1329	18-1330	-	-	-	-	-
I-6/250 CID	18-1308	18-1309	18-1341	-	-	-	-
4.3L/V-6	18-1327	18-1337	-	18-1311	-	-	-
5.0L/305 CID	18-1308	18-1309	18-1341	18-1300	-	-	-
5.7L/350 CID	18-1308	18-1309	18-1341	18-1300	-	-	-
7.4L/454 CID	18-1334	18-1333	18-1332	18-1315	-	-	-
FORD							
5.0L/302 CID	—	-	-	-	-	-	-



One Piece Rear Main Seals

18-1234
Replaces:
3853528

18-0519
Replaces
3852657, 912957



Two Piece Rear Main Seals

18-0528
Replaces:
913745

18-1211
Replaces:
473424



Timing Cover Seals

18-1213
Replaces:
3853341
912989, 914817

18-1230
Replaces:
3853827













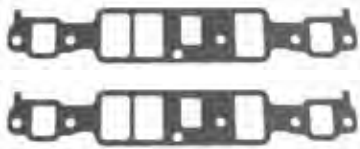

18-1233
Replaces: 3860095

OMC SEAL APPLICATION

Engine Model	2 Piece Rear Main Crankshaft Seal Conv. Rotation (LH)	Timing Cover Seal
GM		
2.5L/153 CID	18-1211 ②	18-1213
3.0L/181 CID	18-1211 ②	18-1213
I-6/230CID	18-1211 ②	18-1213
I-6/250CID	18-1211 ②	18-1213
4.3L/V-6	18-1211 ②	18-1213
5.0L/305 CID	18-1211 ①	18-1213
5.7L/350 CID	18-1211 ①	18-1213
7.4L/454 CID	③	18-1233
FORD		
5.0L/302 CID	18-0528	
5.8L/351 CID	—	18-1230

① Large Journal Crankshaft GM Engines ② For One Piece Seal (LH) Models Use 18-0519 ③ For One Piece Seal (LH) Models Use 18-1234

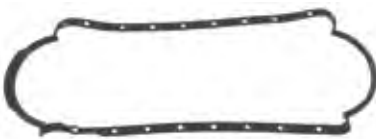
MISCELLANEOUS GASKETS/GASKET SETS

 <p>18-0465 INTAKE MANIFOLD GASKET SET Replaces: 352670 For: GM 454 CID Engines, 325, 330, 340, 350 HP and 454 Magnums, 7.4L</p>	 <p>18-0153 OIL PAN GASKET SET Replaces: 393159, 458625, 357159 For: OMC 5.7L</p>	 <p>18-0340 OIL PAN GASKET SET Replaces: 508713</p>
 <p>18-1239 OIL PAN GASKET Replaces: 914820 For: OMC 3.0L</p>	 <p>18-0348 OIL PAN GASKET SET Replaces: 3931593, 508871</p>	 <p>18-1237 OIL PAN GASKET Replaces: 3856138</p>
 <p>18-0466 OIL PAN GASKET SET Replaces: 393061, 3923440, 3921473</p>	 <p>18-1238 INTAKE GASKET SET Replaces: 3850379, 912979 For: OMC 4.3L 1993-96</p>	 <p>18-1231 INTAKE GASKET Replaces: 3854095</p>
 <p>18-0405 OIL PAN GASKET Replaces: 3852655, 912955 For: OMC 4.3L</p>	 <p>18-0407 OIL PAN GASKET SET Replaces: 508872</p>	 <p>18-0410 INTAKE MANIFOLD GASKET SET Replaces: 988162, 3854406, 986103, 3853912, 986104, 3853913 For: OMC 5.0L & 5.8L (1989-96)</p>
 <p>18-0411 OIL PAN GASKET SET Replaces: 458625, 357159, 508876</p>	 <p>18-1232 OIL PAN GASKET Replaces: 3853510</p>	 <p>18-0868 INTAKE MANIFOLD GASKET SET Replaces: 985630, 3854269 For: OMC 5.7L 1994, 1996-97</p>



Display Package

18-2613
OUTDRIVE GASKET SET
 Replaces: 508105

— CONTAINS —

Part #	Description	O.E. #	Qty.
18-2918	Outdrive Gasket	911836	1
18-2996	Outdrive Seal	911823	1
18-7153	O-Ring	911851	2

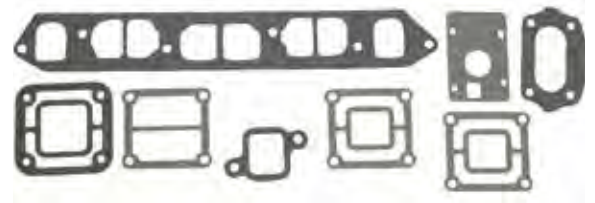

18-4369
EXHAUST MANIFOLD GASKET SET
 For: 2.5L (1985-86) and 3.0L (1985-88)



18-2699
OUTDRIVE GASKET
 For: SX Drives
 Use 18-3721 Mounting Nuts

— CONTAINS —

Part #	Description	O.E. #	Qty.
18-7153	O-Ring	911851	2
18-2996	Outdrive Seal	911823	1



18-4370
EXHAUST MANIFOLD GASKET SET
 For: 100, 120 HP and 2.5L (1965-85)

— CONTAINS —

Part #	Description	O.E. #	Qty.
18-0114	Manifold End Cap Gasket	907761	1
18-2896	Exhaust Manifold Mounting Gasket	311068	1
18-0104	Exhaust Elbow Gasket	907764	1
18-0164	Thermostat Housing Gasket	311069	1
18-0937	Carb. Mtg. Gasket	315055	1
18-2861	Manifold End Cap Gasket	311121	3
18-2875	Elbow To Manifold Gasket	908013	1
18-2858	Thermostat Cover Housing Gasket	314809	1



18-4408
INTAKE MANIFOLD GASKET SET
 Replaces: 912978
 For: GM 4.3L

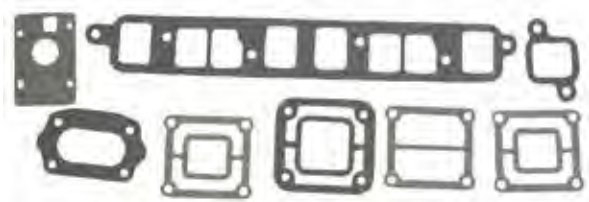

18-4371
EXHAUST MANIFOLD GASKET SET
 For: 140 HP and 3.0L (1973-84)

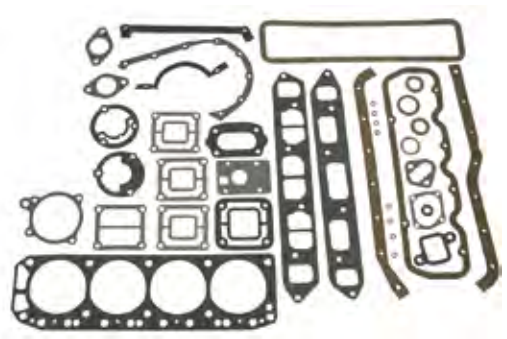

18-4373
OVERHAUL GASKET SET
 For: 110, 120 HP and 2.5L (1965-86)

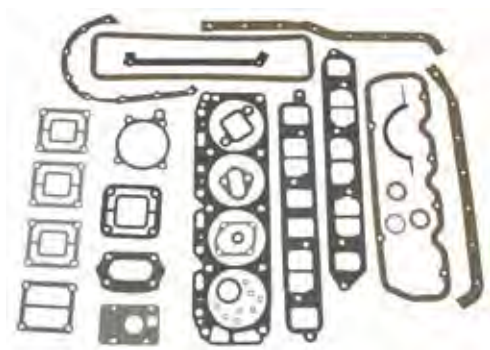











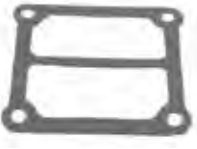







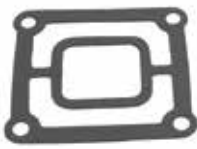

18-4374
OVERHAUL GASKET SET
 For: 140 HP and 3.0L (1973-88)

 <p>18-2946 HEAD GASKET Replaces: 3853336, 908611 For: GM 181 (3.0L) CID Eng.</p>	 <p>18-3874 HEAD GASKET Replaces: 3853511 For: (8.2L) 502 CID</p>	 <p>18-3876 HEAD GASKET Replaces: 3853380, 914971 For: GM 305 (5.0L)/350 (5.7L) CID Eng.</p>	 <p>18-3877 HEAD GASKET Replaces: 914849 For: GM 454 (7.4L) CID Eng.</p>
 <p>18-3878 HEAD GASKET Replaces: 912766 For: Mercruiser 224 (3.7L) CID Eng. Model 470</p>	 <p>18-3879 HEAD GASKET Replaces: 3854299, 912227, 914930 For: GM 262 (4.3L) CID Eng.</p>	 <p>18-3880 HEAD GASKET Replaces: 311210 For: GM 153 (2.5L), (3.0L) CID Eng.</p>	 <p>18-3881 HEAD GASKET Replaces: 908237 For: GM 250 (4.1L) CID (6 cyl) Eng.</p>
 <p>18-3883 HEAD GASKET Replaces: 3853732 For: Ford 302 (5.0L) 351 (5.8L) CID Eng.</p>	 <p>18-3887 HEAD GASKET Replaces: 915325 For: (7.4L) 454 CID GEN V</p>	 <p>18-0434 CARB MOUNTING GASKET Replaces: 909758</p>	<p>PKG OF 2</p>  <p>18-5399 18-5399-9① DISTRIBUTOR CAP GASKET Replaces: 910169</p>
<p>PKG. OF 2</p>  <p>18-0874 18-0874-9① DISTRIBUTOR GASKET For GM V6 & V8 Replaces: 3852109, 312780 For: 2.6L (1989), 3.5L (1989), 4.3L (1987-93), 5.0L (1987-88), 5.7L (1987-92), 7.4L (1988-93), 8.2L (1992-93)</p>	<p>PKG. OF 2</p>  <p>18-0937 18-0937-9① CARB MOUNTING GASKET Replaces: 315055</p>	 <p>18-0435 CARB MOUNTING GASKET Replaces: 908765</p>	<p>PKG. OF 2</p>  <p>18-0876 18-0876-9① FUEL PUMP GASKET For GM 4.3L, 5.0L & 5.7L Replaces: 3852113, 312800</p>
<p>PKG. OF 2</p>  <p>18-0164 18-0164-9① THERMOSTAT GASKET 4 & 6 Cyl. Replaces: 311069 GM 3789161</p>	<p>PKG. OF 2</p>  <p>18-0929 18-0929-9① THERMOSTAT GASKET Replaces: 313416</p>	<p>PKG. OF 2</p>  <p>18-2858 18-2858-9① THERMOSTAT GASKET Replaces: 314809</p>	<p>PKG. OF 2</p>  <p>18-2917 18-2917-9① THERMOSTAT GASKET Replaces: 312797, 3701777 (GM)</p>

SEE PAGES 166-167 FOR OUR COMPLETE LINE OF GASKET SEALANTS

① Priced per Package

<p>PKG. OF 2</p>  <p>18-2947 18-2947-9① THERMOSTAT GASKET Replaces: 310913</p>	<p>PKG. OF 2</p>  <p>18-0104 18-0104-9① EXHAUST ELBOW GASKET Replaces: 907764</p>	<p>PKG. OF 2</p>  <p>18-0114 MANIFOLD END GASKET Replaces: 907761 For GM 4 Cyl.</p>	<p>PKG. OF 2</p>  <p>18-4431 18-4431-9① EXHAUST ELBOW GASKET Replaces: 913783</p>
 <p>18-0430 EXHAUST ELBOW GASKET Replaces: 912477</p>	<p>PKG. OF 2</p>  <p>18-0673 18-0673-9① EXHAUST ELBOW GASKET Replaces: 910113</p>	<p>PKG. OF 2</p>  <p>18-0943-1 18-0943-1-9① EXHAUST ELBOW GASKET Replaces: 909786, 3850496</p>	<p>PKG. OF 2</p>  <p>18-2850 18-2850-9① MANIFOLD END CAP GASKET Replaces: 908935</p>
<p>PKG. OF 2</p>  <p>18-2859 18-2859-9① MANIFOLD END CAP GASKET Replaces: 311131</p>	<p>PKG. OF 2</p>  <p>18-2860 18-2860-9① MANIFOLD END CAP GASKET Replaces: 311130</p>	<p>PKG. OF 2</p>  <p>18-2861 18-2861-9① MANIFOLD END CAP GASKET Replaces: 311121</p>	<p>PKG. OF 2</p>  <p>18-2875 18-2875-9① EXHAUST ELBOW GASKET Replaces: 908013, 3850495</p>
<p>PKG. OF 2</p>  <p>18-2883-1 18-2883-1-9① MANIFOLD END CAP GASKET Replaces: 907775</p>	 <p>18-2541 RUBBER SEAL Replaces: 911704</p>	 <p>18-0401 EXHAUST MANIFOLD GASKET Replaces: 913393 For Ford 140 CID (2.3L)</p>	 <p>18-0431 INTAKE MANIFOLD GASKET Replaces: 912471 For Ford 140 CID (2.3L)</p>
 <p>18-0956 EXHAUST MANIFOLD GASKET Replaces: 912405 460 CID</p>	 <p>18-2912 EXHAUST MANIFOLD GASKET Replaces: 908079</p>	<p>PKG. OF 2</p>  <p>18-2830 EXHAUST MANIFOLD GASKET Inline 6 cyl. Replaces: 907932</p>	 <p>18-2896 EXHAUST MANIFOLD GASKET Replaces: 311068</p>

① Priced per Package

<p>PKG. OF 2</p>  <p>18-2909 18-2909-9① EXHAUST MANIFOLD GASKET Replaces: 915025 GM V-6</p>	 <p>18-0183 EXHAUST MANIFOLD GASKET Replaces: 3853742, 3852455, 908717, 916262 For: OMC 5.0L & 5.8L (1993-96)</p>	 <p>18-0680 EXHAUST MANIFOLD GASKET Replaces: 3853256, 914578</p>	 <p>18-0418 EXHAUST MANIFOLD GASKET Replaces: 909613</p>
<p>PKG. OF 2</p>  <p>18-1204 18-1204-9① EXHAUST MANIFOLD GASKET Replaces: 912164</p>	 <p>18-0892 DEFLECTOR HOSE Replaces: 322411</p>	 <p>18-0664 VALVE COVER GASKET Replaces: 913270, 3852687 For: GM 305/350, 5.0 & 5.7L</p>	 <p>18-2845 VALVE COVER GASKET Replaces: 912965 For GM 305/350 CID (5.0L and 5.7L)</p>
 <p>18-0311 VALVE COVER GASKET Replaces: 3854942 For: 4.3 Litre 262 CID</p>	 <p>18-0346 VALVE COVER GASKET Replaces: 3930912 For: GM 250 CID (4.1L), 160/165/200 (6 cyl.)</p>	 <p>18-0347 VALVE COVER GASKET Replaces: 3852693, 912981, 913277 For: GM 153 & 181 CID (2.5L & 3.0L)</p>	<p>PKG. OF 2</p>  <p>18-0464 18-0464-9① VALVE COVER GASKET Replaces: 912768 For: GM 454/502 CID (7.4L & 8.2L)</p>
 <p>18-0352 VALVE COVER GASKET Replaces: 913758 For: Ford 302/351 CID (5.0L & 5.8L)</p>	 <p>18-0548 ADAPTER TO INTERMEDIATE HOUSING GASKET Replaces: 909515</p>	<p>PKG. OF 2</p>  <p>18-0947 18-0947-9① PIVOT CAP COVER GASKET Replaces: 909529</p>	<p>PKG. OF 2</p>  <p>18-0440 18-0440-9① WATER PASSAGE GASKET Replaces: 915719</p>
 <p>18-0911 WATER PUMP GASKET Replaces: 911698</p>	<p>PKG. OF 2</p>  <p>18-0903 WATER PUMP GASKET Replaces: 3853361 454 CID</p>	 <p>18-0147 WATER PUMP GASKET For Ford V-8 Replaces: 3852824</p>	 <p>18-0327 WATER PUMP GASKET Replaces: 3853342 4 & 6 Cyl.</p>

<p>PKG. OF 2</p>  <p>18-2916 18-2916-9① WATER PUMP HOUSING GASKET Replaces: 911702</p>	 <p>18-0939 18-0939-9① UPPER GEARCASE DIPSTICK GASKET Replaces: 315189</p>	 <p>18-0468 TIMING COVER GASKET Replaces: 3853512, 912954, 3852654, 915326 For: OMC 2.6L, 3.5L (1989), 4.3L (1987-93), 5.0L (1987-88), 5.7L (1987-92, 1994, 1996)</p>	<p>PKG. OF 2</p>  <p>18-0891 18-0891-9① WATER PUMP MOUNTING GASKET Replaces: 3852477, 909835 For: GM 4.3L, 5.0L & 5.8L</p>
<p>PKG. OF 2</p>  <p>18-0893 18-0893-9① WATER PUMP BACK-IN PLATE GASKET Replaces: 3850595 GM 4.3L, 5.0L & 5.7L</p>	<p>PKG. OF 2</p>  <p>18-0322 18-0322-9① REAR SEAL GASKET Replaces: 3852656 GM 5.0L & 5.7L</p>	 <p>18-0329 PUSH ROD/LIFTER COVER GASKET</p>	<p>PKG. OF 2</p>  <p>18-0887 18-0887-9① TIMING COVER GASKET Replaces: 3852691, 912988, 913275 4 & 6 Cyl.</p>
 <p>18-0980 TIMING COVER GASKET Replaces: 3935449 GM 7.4L</p>	<p>PKG. OF 2</p>  <p>18-0880 18-0880-9① SHIFT COVER GASKET Replaces: 911878</p>	<p>PKG. OF 2</p>  <p>18-0166 18-0166-9① GROMMET Replaces: 911705</p>	 <p>18-2815 PUSH ROD COVER GASKET Replaces: 3852692, 913276 For: 3.0L</p>
 <p>18-0190 WIPER GASKET Replaces: 912157</p>	<p>PKG. OF 2</p>  <p>18-2851 18-2851-9① SWIVEL BEARING GASKET Replaces: 313368</p>	<p>PKG. OF 2</p>  <p>18-2863 18-2863-9① TILT CLUTCH COVER GASKET Replaces: 308799</p>	<p>PKG. OF 2</p>  <p>18-2911 18-2911-9① SWIVEL BEARING HOUSING GASKET Replaces: 910236</p>

① Priced per Package

<p>PKG. OF 5</p>  <p>18-2918 18-2918-9① OUTDRIVE GASKET Replaces: 911836, 915840</p>	<p>PKG. OF 5</p>  <p>18-2996 18-2996-9① OUTDRIVE SEAL Replaces: 911823, 3852560</p>	<p>PKG. OF 2</p>  <p>18-0923 18-0923-9① RUBBER SEAL Replaces: 313244</p>	<p>PKG. OF 2</p>  <p>18-0188 18-0188-9① WASHER Replaces: 909748</p>
 <p>18-2387 18-23871-9① (PKG. OF 50) LOWER UNIT DRAIN SCREW Replaces: 307551 Fits: OMC V-6, V-4(1979 & Up), 60-75hp 3 cylinder, 20-35hp (1985-97)</p>	 <p>18-1236 DRAIN SCREW Replaces: 309243 For Cobra Drives & V-6 40-50HP (1989-97)</p>	 <p>18-2378 18-23781-9① (PKG. OF 50 without washer) MAGNETIC DRAIN SCREW Replaces: 318544 Fits: Cobra 2.3, 3.0, 3.8 & 5.8L (1986-92), V-6, V-4(1979 & Up), 60-75hp 3 cyl, 40/50hp (1989-98)</p>	 <p>18-4253-9① 18-42531-9① (PKG. OF 50) DRAIN SCREW O-RING Replaces: 336982 Used w/ 18-1236 Drain Screw</p>
<p>PKG. OF 2</p>  <p>18-2945 18-2945-9① DRAIN SCREW GASKET Replaces: 307552</p>	 <p>18-8369 OIL INDICATOR WITH WASHER Replaces: 914488 Fits: OMC Cobra (1986-93) without cone clutch</p>	<p>PKG. OF 5</p>  <p>18-4248 18-4248-9① 18-42481-9① (PKG. OF 50) DRAIN/FILL PLUG WASHER (Plastic) Replaces: 311598</p>	<p>PKG. OF 5</p>  <p>18-4250 18-4250-9① WASHER Replaces: 911820</p>
 <p>18-0549 PLUG OFF CAP Replaces: 909829 I.D. 1" For V-8 Model Stern Drives and Inboards (1977 to present)</p>	 <p>18-0550 PLUG OFF CAP Replaces: 909830 I.D. 1 1/4" For V-8 Model Stern Drives and Inboards 1977 to present</p>	 <p>18-0518 VALVE STEM SEAL Replaces: 3854956, 914323, 3853132 For: most inline 4 and 6 cyl. GM (Early) and 305-350 CID GM</p>	<p>PKG. OF 8</p>  <p>18-4024 18-4024-9① VALVE STEM SEAL Replaces: 3853226, 914445 For: Chevy 4.3L/5.0L/5.7L</p>

① Priced per Package

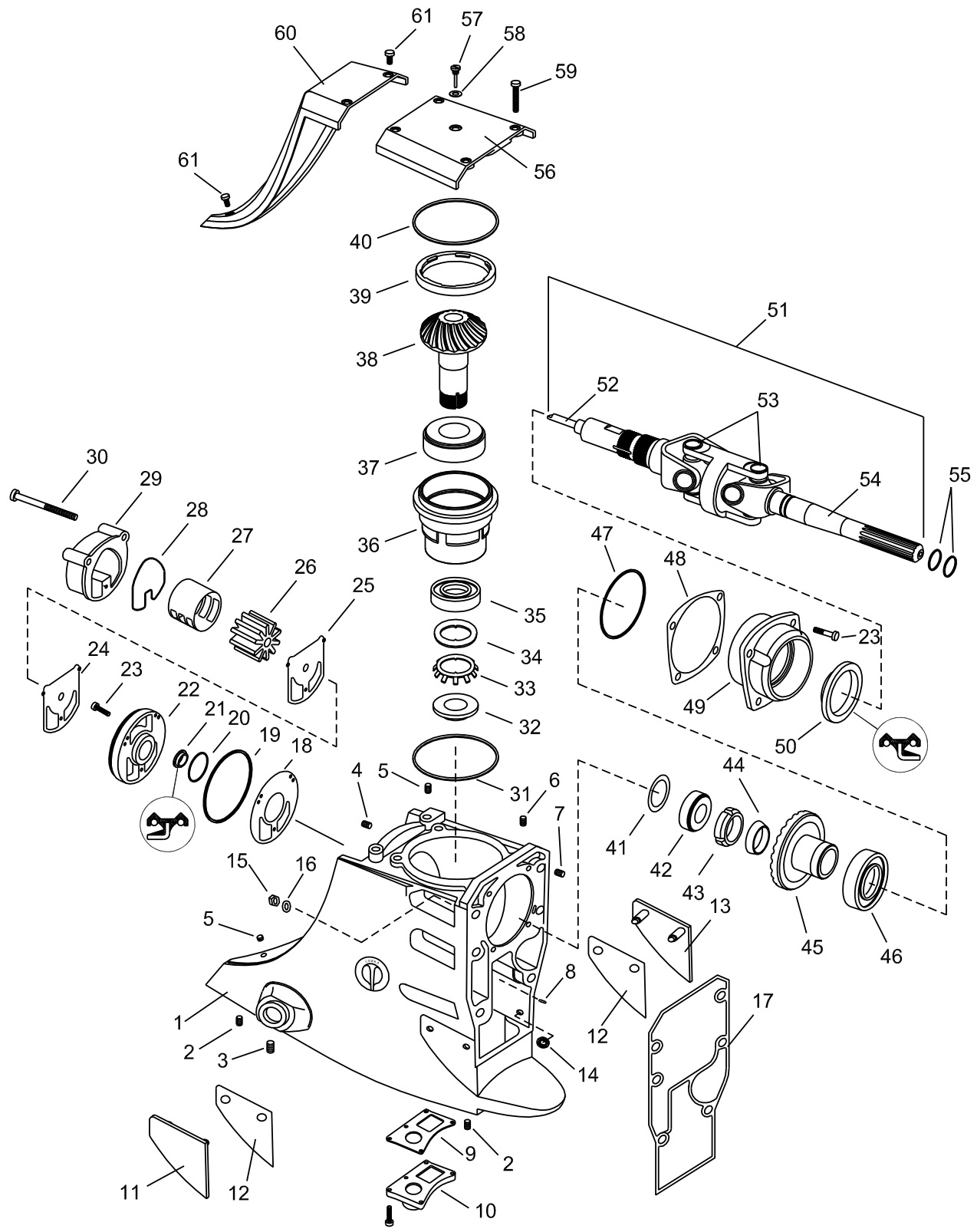

Figure #	Description	Part #	O.E.M. #	Qty.	Figure #	Description	Part #	O.E.M. #	Qty.
1	Upper Gear Housing, Basic w/ Inserts	~	984518	1	32	Pinion Nut	18-3769	911753	1
				5	33	Nut Retainer	18-3610	911752	1
2	Gearcase Insert	NSS	910935	5	34	Pinion Washer	NSS	911697	1
3	Gearcase Insert	NSS	911779,	5	35	Pinion Bearing, Lower	18-1170	983892	1
			3852541		36	Bearing Carrier, Pinion	18-4828	911750	1
4	Gearcase Insert	NSS	910901	5	37	Pinion Bearing, Upper	18-1161	983891	1
5	Gearcase Insert	NSS	911858,	3	38	Gear Set, 21:16 (includes 38 & 45)	18-1600	983825	AR
			3852567		38	Gear Set, 21:18 (includes 38 & 45)	18-1601	983826	AR
6	Gearcase Insert	NSS	910901	4	38	Gear Set, 21:19 (includes 38 & 45)	18-1602	984012	AR
7	Gearcase Insert	NSS	910901	4					
8	Shift Rod Guide	NSS	912137	1	39	Retainer Ring, Pinion Housing	18-3768	911751	1
9	Gasket, Water Passage Cover	18-0884	911733	1	40	O-Ring, Gear Housing Cover	18-7107	313175	1
10	Water Passage Cover	18-4837	911734	1					
11	Thrust Plate, Starboard	NSS	911838,	1	41	Shim, Gear Position, 0.003"	18-02062	911662	AR
			3852562		41	Shim, Gear Position, 0.005"	18-02063	911663	AR
12	Shim, Thrust Plate, 0.015"	18-1713	911839,	AR	41	Shim, Gear Position, 0.007"	18-02064	911664	AR
			3852563		41	Shim, Gear Position, 0.010"	18-02065	911665	AR
13	Thrust Plate, Port	NSS	911837,	1	41	Shim, Gear Position, 0.012"	18-02066	911666	AR
			3852561		41	Shim, Gear Position, 0.015"	18-02067	911667	AR
14	Retainer Ring, Thrust Plate	NSS	910953	4	42	Bearing, U-Joint Shaft	18-1171	983878	1
15	Nut	18-3730	912920,	6	43	Nut, Gear to U-Joint	18-3770	911937	1
			3852648		44	Centering Cone	18-4835	912029	1
16	Washer	NSS	911833	6	45	Gear Set, 21:16 (includes 38 & 45)	18-1600	983825	AR
17	Gasket, Outdrive Mounting	18-2918	911836,	1					
18	Gasket, Adapter to Gear Housing	18-0911	911698	1	45	Gear Set, 21:18 (includes 38 & 45)	18-1601	983826	AR
19	O-Ring, Adapter, Large	18-7407	911700	1					
20	O-Ring, Adapter, Small	18-7403	909316	1	45	Gear Set, 21:19 (includes 38 & 45)	18-1602	984012	AR
21	Water Pump Shaft Seal	18-2068	911701,	1					
22	Adapter, Water Pump to Gear Housing	18-4836	915702,		1	46	Bearing, Bearing Carrier	18-1172	983877
			916058,	47		O-Ring, Bearing Carrier	18-7169	911686	1
23	Screw	18-1598	3853655	6	48	Shim, Bearing Carrier, 0.003", Green	18-0227	911678	AR
			911699						
24	Gasket, Plate to Adapter	18-2916	908668,	1	48	Shim, Bearing Carrier, 0.005", Blue	18-02060	911680	AR
			341013						
25	Plate, Water Pump	18-3121	911703	1	49	Gear Bearing Carrier	18-4838	911683	1
26	Impeller	18-3058	983895,	1	50	Seal, Bearing Carrier	18-2067	911685	1
27	Liner, Water Pump Cover	18-3145	777128		51	U-Joint & Water Pump Shaft Assy	18-2338	983880	1
28	Seal, Water Pump Housing	18-2541	911704	1	52	Stub & Water Pump Shaft	18-6399	984264	1
29	Impeller Housing	18-3206	984744	1					
30	Screw	NSS	912238	3	53	U-Joint Assy	18-2104	912214	2
31	Shim, Bearing Carrier 0.010	18-0207	911668	AR	54	Yoke Shaft	18-2146	912212	1
			911669,		55	O-Ring, U-Joint Shaft	18-7153	911851,	2
31	Shim, Bearing Carrier 0.001	18-0209	911670,	AR	56	Gear Housing Cover	18-4838	911845,	1
			611671,					57	
31	Shim, Bearing Carrier 0.003	18-0211	911672,	AR	58	O-Ring, Oil Indicator	18-7116	303067	1
			911673,					59	
31	Shim, Bearing Carrier 0.003	18-0211	911674,	AR	60	Cover, Water Pump Access	18-4750	983967	1
			911675,					61	
31	Shim, Bearing Carrier 0.003	18-0211	911676,	AR	61	Water Pump Repair Kit w/housing	18-3348	984461,	1
			911677					984744	

AR As required

NSS Not Sold Seperate



SCREWS

Part No.	OE No.	Application
18-1280	317763	115-235 HP (1980-87) Cobra Drives (w/O-Ring)
18-1598	341013	Fits: OMC Cobra (1986-93) without cone clutch
18-1599	123018	Fits: OMC Cobra (1986-93) without cone clutch
18-3135	306643	Cobra Drives
18-4749-9 ^①	3852568	For Cover Assembly: (3 Pack) Fits: 2.3L (1987-90), 2.5L (1986), 2.6L (1989), 3.0L (1986-93), 4.3L (1986-93), 5.0L (1986-94), 5.7L (1986-92), 5.8L (1989-93), 7.4L (1988)

^① PKG of 3, priced per package

GEAR HOUSINGS

Part No.	OE No.	Description	Application
18-4804	984770, 986381	Upper Gear Housing Complete, 21: 16 Ratio	5.7L(1986-93), 5.8L(1986-89,1991-93)
18-4805	984771, 986382	Upper Gear Housing Complete, 21: 18 Ratio	2.5L (1986-89), 3.0L(1986-93), 5.0L(1989-93)
18-4806	984765, 986380	Upper Gear Housing Complete, 21: 19 Ratio	4.3L, 3.0L high altitude OMC Cobra (1986-93)



SHIMS

Part No.	O.E. No.	Size	Part No.	O.E. No.	Size
18-0207 ^①	911668	0.010	18-02064 ^①	911664	0.007
18-0209 ^①	911669, 911670, 911671, 911672, 911673, 911674, 911675, 911676, 911677	0.001	18-02065 ^①	911665	0.010
18-0211 ^①	911669, 911670, 911671, 911672, 911673, 911674, 911675, 911676, 911678	0.003	18-02066 ^①	911666	0.012
			18-02067 ^①	911667	0.015
			18-2229	323362	0.003
			18-2230	323361	0.004
18-0227 ^{① ②}	911678	0.003	18-2231	314745	0.005
18-0229 ^{① ③}	911679	0.004	^① Fits: OMC Cobra (1986-93) without cone clutch ^② Green ^③ Tan ^④ Blue ^⑤ Brown ^⑥ Kit includes 1 each of 18-2229, 18-2230 & 18-2231 NOTE: For shim sizes larger than .010" use shim 18-0207 and appropriate combination of .001" shim (18-0209), and .003" shim (18-0211) to reach desired shim thickness.		
18-1713 ^①	3852563	0.015			
18-1718 ^⑥	-	Kit			
18-02060 ^{① ④}	911680	0.005			
18-02061 ^{① ⑤}	911681	0.010			
18-02062 ^①	911662	0.003			
18-02063 ^①	911663	0.005			



18-9876 SHIM GAUGE TOOL
Replaces: 349957



18-4442 ENGINE ALIGNMENT TOOL
Used to verify engine alignment on Cobra models.

MARINE GRADE 316 STAINLESS STEEL WORM GEAR HOSE CLAMPS



All components are manufactured from Marine Grade 316 stainless steel. These clamps are designed to fit many applications from 5/16" to 7" diameter hoses.

STAINLESS STEEL CLAMPS

Part #	Diameter Size	Std. #	Part #	Diameter Size	Std. #
18-7307	5/16" to 7/8"	006	18-7313	1 9/16" to 2 1/2"	032
18-7308	9/16" to 1 1/16"	010	18-7314	2 9/16" to 3 1/2"	048
18-7309	9/16" to 1 1/4"	012	18-7315	2 1/2" to 4 1/2"	064
18-7310	1 1/16" to 1 1/2"	016	18-7316	3" to 5"	072
18-7311	3/4" to 1 3/4"	020	18-7317	5" to 7"	104
18-7312	1 1/16" to 2"	024			



18-2100 LINK BELT HEAVY DUTY GIMBAL BEARING
Replaces: 983937
Fits all OMC Cobra and King Cobra Drives



18-3763 SHIFT SHAFT
Replaces: 322941
For: V-4/V-6, Cobra, Stringer



18-2337 STUB SHAFT
Replaces: 3850814
Fits: All Cobra 1994-Up except King Cobra



18-6399
SHAFT & STUB ASSEMBLY
 Replaces: 984264
 For: Cobra Drives- 232, 302(1986-90), 252(1986), 262, 350, 460(1989), 432, 434, 502(1986-92), 504(1986-88), 574(1986-92), 584(1989-93), 754(1987-88)



18-2104
U-JOINT
 Heavy Duty
 Replaces: 912214, 915716
 Fits OMC Cobra Drives (1986-89) Includes straight grease fitting and 90° fitting (Rockwell)



18-2174
U-JOINT
 Heavy Duty
 Replaces: 915717, 3850812
 Fits OMC Cobra and King Cobra Drives (1990 & ABOVE) Includes straight grease fitting and 90° fitting. (Rockwell)



18-2338
U-JOINT
 Replaces: 983880
 For: 1986-93 OMC Cobra



18-2339
U-JOINT ASSEMBLY
 Replaces: 3852384
 Fits: All Cobra 1994-Up except King Cobra



18-2146
UNIVERSAL YOKE ASSEMBLY
 Replaces: 912212, 3850815
 For: All Cobra (1986-Up)



18-3770
U-JOINT NUT
 Replaces: 911937
 For: 232, 252, 262, 302, 350, 432, 434, 460, 502, 504, 574, 584, 744, 754, (1987-93)

Year	Model		U-joint #	U-joint Assy. OE #	Long Yoke #	Long Yoke OE #	Short Yoke #	Short Yoke OE #
1986	2.3L, 3.0L, 4.3L, 5.7L	②	18-2338	983880	18-2146	912212	18-6399	984264
1987-88	2.3L, 3.0L, 4.3L, 5.0L, 5.7L, 7.5L	②	18-2338	983880	18-2146	912212	18-6399	984264
1989	2.3L, 3.0L, 4.3L, 5.0L, 5.7L, 5.8L, 7.5L	②	18-2338	983880	18-2146	912212	18-6399	984264
1990	2.3L, 3.0L, 4.3L, 5.0L, 5.7L, 5.8L	②	18-2338	983880	18-2146	912212	18-6399	984264
1990	5.7L, 7.4L, 7.5L	③	N/A	986191	18-2146	912212	N/A	914646
1991	3.0L, 4.3L, 5.7L, 5.8L	②	18-2338	983880	18-2146	912212	18-6399	984264
1991	7.4L	③	N/A	986191	18-2146	912212	N/A	914646
1992-93	3.0L, 3.2L, 4.3L, 5.0L, 5.7L, 5.8L	②	18-2338	983880	18-2146	912212	18-6399	984264
1992-93	3.0L, 3.2L, 4.3L, 5.0L, 5.7L, 5.8L, 7.4L, 8.2L	③	N/A	986191	18-2146	912212	N/A	914646
1994	3.0L, 4.3L, 5.0L, 5.7L, 5.8L	①③	18-2339	3852384	18-2146	3850815	18-2337	3850814
1994	5.8L, 7.4L	③④	N/A	3853937	18-2146	3850815	N/A	3853563
1995	3.0L, 4.3L, 5.0L, 5.8L	③	18-2339	3852384	18-2146	3850815	18-2337	3850814
1995	7.4L	③	N/A	3853937	18-2146	3850815	N/A	3853563
1996	3.0L, 4.3L, 5.0L, 5.7L, 5.8L, 7.4L	③	18-2339	3852384	18-2146	3850815	18-2337	3850814
1997	3.0L, 4.3L, 5.7L, 7.4L	③	18-2339	3852384	18-2146	3850815	18-2337	3850814
1998	3.0L, 4.3L, 5.0L, 5.7L, 7.4L, 8.2L	③	18-2339	3852384	18-2146	3850815	18-2337	3850814

① Excludes Model 58FBPMDA ② Used where raw w/p is located on outdrive ③ Used where raw w/p is located on engine ④ Includes Model 58FBPMDA



18-2772-1
TRANSOM SEAL KIT
 For: SX Cobra Drives with cone clutch

— CONTAINS —

Part #	Description	O.E. #	Qty.
18-2100	Gimbal Bearing	3853807	1
18-2765	Bellows	3854127	1
18-1074	Bellows	3850426-2	1
18-2996	Seal	3852560, 911823	1
18-7315	Hose Clamp	853012-3	1



18-2771
BELLOWS KIT
 For: OMC Cobra without cone clutch

— CONTAINS —

Part #	Description	O.E. #
18-2613	Outdrive Gasket Set	—
18-2765	U-Joint Bellows	983973, 987467
18-2764	Exhaust Bellows	914036
18-2763	Shift Cable Bellows	911826
18-2100	Gimbal Bearing	983937
18-7315	Hose Clamp	—



**18-2128
CENTER SOCKET**
Replaces:
912213, 3850813
Fits all OMC Cobra



**18-2745
EXHAUST BOOT**
Replaces: 912374
Fits 5.7L & 7.5L (1986 & later)



**18-1074
EXHAUST BELLOW**
Replaces: 3850426
All cone clutch models (1994-up)
not using exhaust boot



**18-2763
SHIFT CABLE
BELLOWS**
Replaces: 911826
ALL COBRA



**18-2764
EXHAUST BELLOWS**
Replaces: 914036
All clutch dog Cobra models
(1986-93)



**18-2765
U-JOINT BELLOWS**
Replaces: 983973,
987467, 3854127
All clutch dog Cobra models (1986-93)



**18-21754
ENGINE COUPLER**
Replaces: 986232, 984537
Fits: 7.5L / 460 King Cobra 1987-90



**18-21751
ENGINE COUPLER**
Replaces: 3853962,
983902, 986338
Fits: 2.5L (1986), 3.0L (1986-90), (4.3L,
5.0L, 5.7L) (1986) KW & KWB suffix only,
7.4L (1990-98), 8.2L (1992-93, 1998)



**18-21752-1
ENGINE COUPLER**
Replaces: 3858437, 984290,
986120, 3853917
Fits: 4.3L (1986-98), 5.0L (1986-88, 1998)
5.7 (1986-92, 1994, 1996-98)



**18-21753
ENGINE COUPLER**
Replaces: 3853862
Fits: 5.0L & 5.8L (1989-96)



**18-21755
ENGINE COUPLER**
Replaces: 984629
2.3L Cobra



**18-2533
TRANSOM SEAL**
Replaces: 911797



**18-2767
TRANSOM SEAL**
Replaces: 313080
(1967-77) 120 HP and UP



**18-2768
TRANSOM SEAL**
Replaces: 909527
(1978-86) — ALL



**18-2245-1
SHIFT CABLE
ASSEMBLY**
Replaces: 987661
For: 1988-1993 OMC Cobra (except King)
without cone clutch



**18-2246
SHIFT CABLE ASSEMBLY**
Replaces: 987678
For: King Cobra



**18-2178
BALL GEAR KIT**
(1973-86)

— CONTAINS —

Part #	Desc.	O.E. #	Qty.	Part #	Desc.	O.E. #	Qty.
18-7121	O-Ring	308621	1	18-3725	Locknut	908064	2
18-4251	Plug	908062	2	18-7401	O-Ring	908383	1
18-2176	Ball Gear	908063	1	18-2071	Oil Seal	981195	2
18-2177	Ball Gear	908069	1	18-2072	Oil Seal	981196	2

 <p>18-2176 BALL GEAR (Intermediate Housing) Replaces: 908063 (1973-86)</p>	 <p>18-2177 BALL GEAR (Upper Gearcase) Replaces: 908069 1973-86</p>	 <p>18-3769 PINION NUT Replaces: 911753 For: 115 (1994-97), 232 (1987-90), 252 (1986), 262, 350, 460 (1989), 302, 574 (1986-92), 432 (1986-93), 502 (1988-93), 504, 754 (1986-88), .584 (1989-93), 744 (1988), 90 Jet (1994-95)</p>	 <p>18-3719 PINION NUT Replaces: 314730 (⁵/₈ - 18)</p>	
<p>PKG. OF 5</p>  <p>18-3725 18-3725-9① BALL GEAR NUT Replaces: 908064</p>	<p>PKG. OF 2</p>  <p>18-3731 18-3731-9① LOCKNUT Replaces: 907866 ³/₄ - 16</p>	<p>PKG. OF 5</p>  <p>18-4251 18-4251-9① PLUG Replaces: 908062 O.D. 1.748</p>	 <p>18-4835 CENTERING CONE Replaces: 912029 Fits: OMC Cobra (1986-93) without cone clutch</p>	 <p>18-1154 BALL BEARING Replaces: 377139</p>
 <p>18-1161 TAPERED ROLLER BEARING Replaces: 983891</p>	 <p>18-1170 LOWER PINION BEARING Replaces: 983892</p>	 <p>18-1171 U-JOINT SHAFT BEARING Replaces: 983878</p>	 <p>18-1172 CARRIER BEARING Replaces: 983877 For: 1986-95 Cobra</p>	
 <p>18-1158 CARRIER BEARING Replaces: 387247</p>	 <p>18-1350 CARRIER BEARING Replaces: 379504</p>	 <p>18-1351 CARRIER BEARING Replaces: 382407 COBRA</p>	 <p>18-1117 PINION BEARING Replaces: 387817</p>	 <p>18-1357 PINION BEARING Replaces: 384195 COBRA</p>
 <p>18-1358 REVERSE GEAR BEARING Replaces: 389039 COBRA</p>	 <p>18-1365 THRUST BEARING Replaces: 387656 COBRA DRIVE SHAFT</p>	 <p>18-1366 THRUST BEARING Replaces: 382408 COBRA REVERSE GEAR</p>	 <p>18-1370 THRUST FORWARD BEARING Replaces: 389042</p>	 <p>18-1371 THRUST FORWARD BEARING Replaces: 385043 COBRA</p>

① Priced per Package



APPLICATION BEINGS ON NEXT PAGE



OMC 400 & 800 SERIES GEARCASE BEARINGS



HP	Year	Pinion Bearing	Drive Shaft Bearing	Carrier Aft Bearing	Carrier Fore Bearing	Forward Thrust Bearing	Reverse Thrust Bearing	Housing Bearing
120	1978-81	18-1357	18-1365	18-1350	18-1351	18-1371	18-1366	—
2.5L	1982-86	18-1357	18-1365	18-1350	18-1351	18-1371	18-1366	18-1351
140	1978-81	18-1357	18-1365	18-1350	18-1351	18-1371	18-1366	—
3.0L	1982-86	18-1357	18-1365	18-1350	18-1351	18-1371	18-1366	18-1351
185/3.8L	1978-85	18-1117	18-1365	18-1158	18-1351	18-1370	18-1366	18-1358
4.3L	1985-86	18-1117	18-1365	18-1158	18-1351	18-1370	18-1366	18-1358
200/5.0L	1979-86	18-1117	18-1365	18-1158	18-1351	18-1370	18-1366	18-1358
225	1978	18-1117	18-1365	18-1158	18-1351	18-1370	18-1366	18-1358
230/530L	1979-86	18-1117	18-1365	18-1158	18-1351	18-1370	18-1366	18-1358
240	1978	18-1117	18-1365	18-1158	18-1351	18-1370	18-1366	18-1358
250	1979	18-1117	18-1365	18-1158	18-1351	18-1370	18-1366	18-1358
260/5.7L	1979-86	18-1117	18-1365	18-1158	18-1351	18-1370	18-1366	18-1358

OMC COBRA GEAR HOUSING BEARINGS

HP	Year	Pinion Bearing	Drive Shaft Bearing	Carrier Aft Bearing	Carrier Fore Bearing	Forward Thrust Bearing	Reverse Thrust Bearing	Housing Bearing
2.3L	1987	18-1357	18-1365	18-1350	18-1351	18-1371	18-1366	18-1351
2.3L	1988-90	18-1357	18-1365	18-1350	18-1351	18-1371	18-1366	—
2.5L	1986	18-1357	18-1365	18-1350	18-1351	18-1371	18-1366	18-1351
3.0L	1986-87	18-1357	18-1365	18-1350	18-1351	18-1371	18-1366	18-1351
3.0L	1988-89	18-1357	18-1365	18-1350	18-1351	18-1371	18-1366	—
3.0L	1990-91	18-1117	18-1365	18-1158	18-1351	18-1370	18-1366	—
3.0L/3.0L HO	1992-93	18-1117	18-1365	—	18-1351	18-1370	18-1366	—
4.3L	1986-87	18-1117	18-1365	18-1158	18-1351	18-1370	18-1366	18-1358
4.3L	1988-91	18-1117	18-1365	18-1158	18-1351	18-1370	18-1366	—
4.3L/4.3L HO	1992-93	18-1117	18-1365	—	18-1351	18-1370	18-1366	—
5.0L	1986-87	18-1117	18-1365	18-1158	18-1351	18-1370	18-1366	18-1358
5.0L	1988-91	18-1117	18-1365	18-1158	18-1351	18-1370	18-1366	—
5.0L/5.0L HO	1992-93	18-1117	18-1365	—	18-1351	18-1370	18-1366	—
5.7L	1986-87	18-1117	18-1365	18-1158	18-1351	18-1370	18-1366	18-1358
5.7L	1988-91	18-1117	18-1365	18-1158	18-1351	18-1370	18-1366	—
5.7L	1992-93	18-1117	18-1365	—	18-1351	18-1370	18-1366	—
5.8L	1989-91	18-1117	18-1365	18-1158	18-1351	18-1370	18-1366	—
5.8L	1992-93	18-1117	18-1365	—	18-1351	18-1370	18-1366	—

 <p>18-0195 THRUST WASHER Replaces: 314731 COBRA</p>	 <p>18-0198 FORWARD GEAR THRUST WASHER Replaces: 324766</p>	<p>PKG. OF 2</p>  <p>18-2243 18-2243-9 ① DETENT BALL Replaces: 316506 For: V-4 & V-6 gearcase OMC Sterndrive 400 Series (1978-79); 800 Series (1978)</p>
---	--	--

 <p>18-1501 DETENT BALL Replaces: 160084 For: Cobra drives (1980& Earlier)</p>	 <p>18-1732 DRIVE SHAFT RETAINER Replaces: 338504 For: V4 & V6 driveshafts</p>
---	---

 <p>18-1701 LOWER DRIVE SHAFT Replaces: 911693 For: Cobra Drives 262, 302, 350, 432, 434, 502, 504, 574, 584</p>	 <p>18-2183 DRIVE SHAFT Replaces: 909121</p>
---	--

① Priced per Package



18-2184
DRIVE SHAFT
Replaces: 908087



18-2185
DRIVE SHAFT
Replaces: 909753



18-2186
DRIVE SHAFT
Replaces: 982424
800 Drives



18-2187
PROP SHAFT
Replaces: 395209
Cobra & Late Model 800 Drives



18-2251
PROP SHAFT
Replaces: 435022, 433017, 436740



18-2252
PROP SHAFT
Replaces: 387818, 436888



18-2216
SLIDING CLUTCH
Replaces: 337772, 337774,
334516, 336562, 910995



18-2220
SLIDING CLUTCH
Replaces: 323664, 320630



18-2383
SLIDING CLUTCH
Replaces: 914716, 915272
For: 3.0L (GM), 4.3L (GM), 5.0L (Ford), 5.7L (Ford),
5.8L (Ford) (1990-91)



18-2218
FORWARD GEAR SET
Replaces: 434063, 987966,
985050, 436746



18-2219
REVERSE GEAR
Replaces: 333077,
317838, 340490



18-1600
UPPER GEAR KIT
with bearing
Replaces: 983825
For: 5.7, 5.8L V-8 Cobra drives (21:16 ratio)



18-1601
UPPER GEAR KIT
with bearing
Replaces: 983826
For: 5.0L V-8 engines-Cobra drives (21:18 ratio)



18-1602
UPPER GEAR KIT
Replaces: 984012
For: 4.3L V-6 engines-Cobra drives (21:19 ratio)



18-2217
GEAR SET

—CONTAINS—

Part #	Desc.	O.E.#
NSS	Forward Gear	435020
NSS	Reverse Gear	910994
18-2216	Sliding Clutch	337772

APPLICATION BEGINS ON NEXT PAGE

SHAFT/GEAR/SLIDING CLUTCH APPLICATION

Model	Year	Bearing Carrier Shaft	Short/Long Water Pump Shaft	Drive Shaft	Prop Shaft	Forward Gear	Reverse Gear	Sliding Clutch
100 thru 165	1973	—	18-2185	—	—	—	—	—
120 thru 190	1974-75	—	18-2185	—	—	—	—	—
120 thru 235 ⑥	1976-77	—	18-2184	—	—	—	—	—
120 thru 190 ⑤	1976	—	18-2185	—	—	—	—	—
120/140 ⑤	1977	—	18-2185	—	—	—	—	—
120/140	1978-81	18-2183	18-2185	—	18-2252	—	—	18-2220
120 thru 235 ⑥	1977	—	18-2184	—	—	—	—	—
175/190/235 ⑤	1977	18-2183	18-2185	—	—	—	—	—
185	1978	18-2183	18-2185	18-2186	—	—	—	—
185	1980-81	18-2183	18-2185	18-2186	—	—	—	—
200	1979	18-2183	18-2185	18-2186	—	—	—	—
200	1980-81	18-2183	18-2185	18-2186	—	—	—	—
225/245	1973-75	—	18-2184	—	—	—	—	—
225	1978	18-2183	18-2185	18-2186	—	—	—	—
225	1979	—	—	18-2186	—	—	—	—
225	1980	—	—	18-2186	—	—	—	—
225	1981	—	—	18-2186	—	—	—	—
230	1979	18-2183	18-2185	18-2186	—	—	—	—
230	1980-81	18-2183	18-2185	18-2186	—	—	—	—
235	1975	18-2183	18-2185	—	—	—	—	—
235 ⑤	1976-77	18-2183	18-2185	—	—	—	—	—
240	1978	18-2183	18-2185	18-2186	—	—	—	—
240	1979	—	—	18-2186	—	—	—	—
240	1980-81	—	—	18-2186	—	—	—	—
250	1979	18-2183	18-2185	18-2186	—	—	—	—
260	1979	18-2183	18-2185	18-2186	—	—	—	—
260	1980-81	18-2183	18-2185	—	—	—	—	—
262	1989	—	—	—	18-2187	—	—	—
2.3/3.0	1987-89	—	—	—	18-2252	—	18-2219	—
2.3	1990	—	—	—	18-2252	—	—	—
2.5	1986	18-2183	18-2185	—	18-2252	—	18-2219	—
2.5	1982-87	18-2183	18-2185	—	18-2252	18-2218	18-2219	—
350 ③	1988-89	—	—	—	18-2187	18-2218	—	—
3 ①	1982-86	18-2183	18-2185	—	18-2252	18-2218	18-2219	18-2216
3.0/4.3 ③	1990-91	—	—	—	18-2187	—	—	18-2383
3.0/4.3	1992-93	—	—	—	18-2251	—	—	18-2383
3.0 H.O.	1990-91	—	—	—	18-2187	—	—	18-2383
3.0 H.O.	1992-93	—	—	—	18-2251	—	—	18-2383
3.8	1982-86	18-2183	18-2185	18-2186	18-2187	—	—	18-2216
460 ③	1988-89	—	—	—	18-2187	—	—	18-2216
4.3 ①	1985-86	18-2183	18-2185	18-2186	18-2187	—	—	18-2216
4.3 ②	1986-87	—	—	—	18-2187	—	—	—
4.3 ③	1988-91	—	—	—	18-2187	—	—	18-2383 ⑨
4.3 H.O.	1990-91	—	—	—	18-2187	—	—	18-2383
4.3 H.O.	1992-93	—	—	—	18-2251	—	—	18-2383
5.0/5.7	1982-83	18-2183	18-2185	18-2186	—	—	—	18-2216
5.0/5.7 ①	1984-86	18-2183	18-2185	18-2186	18-2187	—	—	18-2216
5 ②	1986-87	—	—	—	18-2187	—	—	—
5	1988	—	—	—	18-2187	—	—	—
5 ③	1988-91	—	—	—	18-2187	—	—	18-2383 ⑨
5.0/5.7	1992	—	—	—	18-2251	—	—	18-2383
5.0 H.O.	1990-91	—	—	—	18-2187	—	—	18-2383
5.0 H.O.	1992-93	—	—	—	18-2251	—	—	18-2383
5.7	1987-88	—	—	—	18-2187	—	—	—
5.7 ③	1988-89	—	—	—	18-2187	—	—	—
5.7 ⑥ ③	1990-92	—	—	—	18-2187	—	—	18-2383
5.8 ③	1989-90	—	—	—	18-2187	—	—	18-2383 ⑨
5.8	1991	—	—	—	18-2187	—	—	18-2383
5.8	1992-93	—	—	—	18-2251	—	—	18-2383
7.5	1987	—	—	—	18-2187	—	—	18-2216

① Except Cobra
② Cobra

③ Right hand rotation drive
⑤ Low profile

⑥ High profile
⑧ Except L.E. models

⑨ 1990-93 models only



18-3767 BEARING ASSEMBLY & HOUSING
Replaces: 389455
For: V-4, V-6 Cobra Stringer



18-1702 CARRIER BEARING
Replaces: 438039, 5000074
For: 1 3/16" diameter prop shaft-Cobra drives (1986-90) Fits all stringer mounts except 2.5L & 3.0L (1978-85)



18-1703 CARRIER BEARING
Replaces: 434400, 435096, 438040, 5000363, 5004257
For: 1 1/4" diameter prop shaft Cobra drives (1991-93)



18-4828
PINION BEARING CARRIER
 Replaces: 911750
 Fits: OMC Cobra (1986-93) without cone clutch



18-1099
BEARING HOUSING & SEAL ASSEMBLY
 Replaces: 982422
 For: OMC Stringer Drive-120, 140, 170, 200, 230, 260, (1981), 252, 302, 382, 502, 504 & 574 (1982-85), 432 (1985)



18-1343
BEARING CARRIER RETAINING TAB
 Replaces: 333957
 For: Cobra drives & V-6



18-0655
SHIFT ROD
 Replaces: 914736
 3.0L (1990-1993), 4.3L, 5.0L, 5.7L, 5.8L (1986-1993)



18-0647
SHIFT ROD ASSEMBLY
 Replaces: 986658
 3.0L (1990-1993), 4.3L, 5.0L, 5.7L, 5.8L (1986-1993)



18-0652
ROD END, SHIFT
 Replaces: 914723
 3.0L (1990-1993), 4.3L, 5.0L, 5.7L, 5.8L (1986-1993)



18-0653
SCREW, SHIFT ROD END
 Replaces: 308825
 3.0L (1990-1993), 4.3L, 5.0L, 5.7L, 5.8L (1986-1993)



18-0654
NUT, SHIFT ROD END
 Replaces: 914743
 3.0L (1990-1993), 4.3L, 5.0L, 5.7L, 5.8L (1986-1993)



18-3766
SHIFT CRADLE
 Replaces: 334163
 For: V-4/V-6, Cobra, Stringer



18-3610
RETAINER NUT
 Replaces: 911752
 Fits: OMC Cobra (1986-93) without cone clutch



18-3768
COVER NUT
 Replaces: 911751
 For: Cobra Drives 115 (1994-97), 232 (1987-90), 252 (1986) 262 (1989), 302 (1987)



18-1500
INTAKE WATER SCREEN
 Replaces: 337778
 For: 100, 120, 125, 140, 150, 175, 200, 225 (1993) (OMC Cobra & V6)



18-4750
COVER ASSEMBLY
 Replaces: 983967
 Fits: 2.3L (1987-90), 2.5L (1986), 2.6L (1989), 3.0L (1986-93), 4.3L (1986-93), 5.0L (1986-94), 5.7L (1986-92), 5.8L (1989-93), 7.4L (1988)



18-1714
CLUTCH DOG PIN
 Replaces: 313448
 For: 50-85, 100, 135, 140, 150, 175, 200, 235 (1969-82) (OMC Stringer drive)



18-2399
CLUTCH DOG
Replaces: 324369
For: V-4 & V-6



18-4222
THRUST WASHER
Replaces: 318841



18-4223
THRUST WASHER
Replaces: 333592



18-4228
PROP SPACER
Replaces: 315810



18-4194
PROP SPACER
Replaces: 3852350
For: 1994 King Cobra Lower Units



18-4231
PROP SPACER
Replaces: 320570



18-3705
18-3705-9①
PROP NUT
Replaces: 314503



18-3708-1
PROP NUT & KEEPER
Replaces: 398042



18-3730
LOCK NUT
Replaces: 3852648
For: Cobra & King Cobra 1987-94



18-3733
PROP NUT KIT
For: SX Cobra



18-3715
PROP NUT KIT

— CONTAINS —

Part #	O.E. #	Description
18-3708-1	398042	Prop Nut/Keeper
18-3741	309955	Cotter Pin
18-4231	320570	Prop Spacer



18-3716
PROP NUT KIT
Replaces: 175267

— CONTAINS —

Part #	O.E. #	Description
18-3705	314503	Prop Nut
18-3742	314502	Cotter Pin
18-4238	315810	Prop Spacer



18-4444
PROP WRENCH
FOR ALL COBRA



18-2156
TILT SHAFT
Replaces: 980183
I/O 1964-86
EXCEPT COBRA



COTTER PINS
18-3741 **18-3742**
18-3741-9① **18-3742-9①**
Replaces: 314502
309955 314502



18-9098
TRAILERING CLIPS
Replaces: 174448
Set of 2
For all Cobra Stern Drives

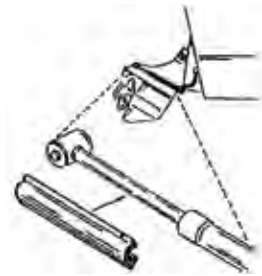

APPLICATION BEGINS ON NEXT PAGE

① Priced per Package

② Items ending in "D" are Display Packaged - Regular number is Non-Display

NUT/SPACER/WASHER/COTTER PIN/PROP NUT KIT APPLICATION

Model	Year	Nut	Spacer	Washer	Cotter Pin	Prop Nut Kit	Model	Year	Nut	Spacer	Washer	Cotter Pin	Prop Nut Kit
120	1978-81	18-3705	18-4228	18-4222	18-3742	18-3716	460	1989-90	18-3708-1	18-4231	18-4223	18-3741	18-3715
140	1978-81	18-3705	18-4228	18-4222	18-3742	18-3716	502	1992	18-3708-1	18-4231	18-4223	18-3741	18-3715
185	1978-80	18-3708-1	18-4231	18-4223	18-3741	18-3715	2.3	1987-90	18-3705	18-4228	18-4222	18-3742	18-3716
200	1979-81	18-3708-1	18-4231	18-4223	18-3741	18-3715	2.5	1982-86	18-3705	18-4228	18-4222	18-3742	18-3716
225	1978	18-3708-1	18-4231	18-4223	18-3741	18-3715	3	1982-89	18-3705	18-4228	18-4222	18-3742	18-3716
230	1979	18-3708-1	18-4231	18-4223	18-3741	18-3715	3	1990-92	18-3708-1	18-4231	18-4223	18-3741	18-3715
240	1978	18-3708-1	18-4231	18-4223	18-3741	18-3715	3.8	1981-85	18-3708-1	18-4231	18-4223	18-3741	18-3715
260	1979-81	18-3708-1	18-4231	18-4223	18-3741	18-3715	4.3	1985-92	18-3708-1	18-4231	18-4223	18-3741	18-3715
262	1987-89	18-3708-1	18-4231	18-4223	18-3741	18-3715	5	1982-92	18-3708-1	18-4231	18-4223	18-3741	18-3715
350	1988-91	18-3708-1	18-4231	18-4223	18-3741	18-3715	5.7	1979-92	18-3708-1	18-4231	18-4223	18-3741	18-3715
351	1992	18-3708-1	18-4231	18-4223	18-3741	18-3715	5.8	1989-92	18-3708-1	18-4231	18-4223	18-3741	18-3715
454	1990-92	18-3708-1	18-4231	18-4223	18-3741	18-3715	7.5	1987	18-3708-1	18-4231	18-4223	18-3741	18-3715

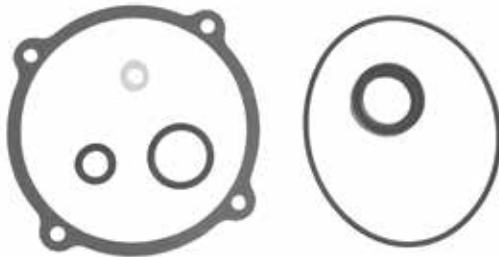

**18-2698
CLUTCH HOUSING SEAL KIT**

Fits: All models 1977 & below

— CONTAINS —

Part #	Desc.	O.E. #	Qty.
18-7114	O-RING	302540	1
18-7400	O-RING	908194	1
18-7952	OIL SEAL	911019	1
18-2863	GASKET, COVER	308799	1
18-4248	GASKET, OIL DRAIN	311598	1
18-0939	GASKET, DIPSTICK	315189	1

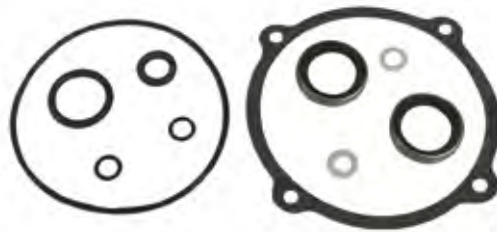

**18-8360
CLUTCH HOUSING SEAL KIT**

Fits: All models 1978 & above

— CONTAINS —

Part #	Desc.	O.E. #	Qty.
18-2060	OIL SEAL	321467	2
18-7114	O-RING	302540	1
18-7168	O-RING	202893	2
18-7400	O-RING	908194	1
18-2863	GASKET, COVER	308799	1
18-4248	GASKET, OIL DRAIN	311598	2
18-0939	GASKET, DIPSTICK	315189	1

HP	Year	Clutch Pack Seal Kit	HP	Year	Clutch Pack Seal Kit	HP	Year	Clutch Pack Seal Kit	HP	Year	Clutch Pack Seal Kit
80	1968-1969	18-2698	140	1980-1981	18-8360 ^③	190	1974-1977	18-2698	230	1980-1981	18-8360 ^②
90	All	18-2698	3.0L	1982-1985	18-8360	200	1966-1968	18-2698	235	All	18-2698
100	1972-1973	18-2698	155	1967-1972	18-2698	200	1979-1980	18-2698 ^①	240	1978	18-2698
120	1965-1978	18-2698	165	1972-1976	18-2698	200	1980-1981	18-8360 ^②	245	1972-1975	18-2698
120	1979-1980	18-2698 ^①	3.8L	1981-1983	18-8360	5.0L	1982-1985	18-8360	250	1979	18-2698
120	1980-1985	18-8360 ^③	170	1974	18-2698	210	1968-1970	18-2698	260	1979-1980	18-2698 ^①
2.5L	1982-1985	18-8360	175	1975-1977	18-2698	215	1971	18-2698	260	1980-1981	18-8360 ^②
140	1973-1978	18-2698	185	1967-1968	18-2698	225	All	18-2698	5.7L	1982-1985	18-8360
140	1979-1980	18-2698 ^①	185	1978	18-2698	230	1979-1980	18-2698 ^①			

① 1980 Models with the "C" suffix

② 1980 Models with "K" or "U" suffix

③ 1980 Models with "C1" suffix

**Zinc is for saltwater only applications.
Magnesium is for fresh water only applications.
Aluminum is for brackish water, or if boat is used in both fresh and salt environments.**



**⑤ 18-6019
ANODE**
Replaces: 982277, 982438
For intermediate housing on
Stringer Drive models



**⑤ 18-6020
ANODE**
Replaces: 976669
For Stringer Drive models with central
grounding point on boat hull



**⑤ 18-6024
④ 18-6024A
ANODE**
Replaces: 393023, 436745
(1982-87) For use on gearcases



**⑤ 18-6025
ANODE**
Replaces: 433458, 398331

④ Aluminum

⑤ Zinc



③ **18-6027**
ANODE
 Replaces: 392123
 For exhaust housing,
 V4 & V6 (1983-90)



③ **18-6028**
 ① **18-6028A**
 ② **18-6102**
ANODE
 Replaces: 984513,
 3853818, 3855412
 For use on Gearcases: 2.3L (1987-90),
 2.6L/3.5L/4.6L (1989), 3.0L/4.3L/5.0L/5.8L
 (1987-93), 5.7L (1987-92), 7.4L (1987-88)



③ **18-6029**
ANODE
 Replaces: 397768



③ **18-6095**
 ① **18-6095A**
ANODE
 Replaces: 431708
 For use on gearcases (1988-90)



③ **18-6101**
ANODE
 Replaces: 983494
 For: Cobra Lower Unit (1987)
 2.5, 3.0, 4.3, 5.0, 5.7



③ **18-6103**
 ① **18-6103A**
ANODE
 Replaces: 984547
 For use on Transom Mounts:
 2.3L/3.0L (1987-89), 2.6L (1989)



③ **18-6155Z**
ANODE KIT
 For: Cobra Drives except King Cobra

PKG. OF 5



18-3722
18-3722-9④
STAINLESS STEEL LOCKNUT
 Replaces: 121731
 (1/4"—28)



18-2138
PIVOT PIN BEARING
 Replaces: 911787
COBRA
(2 per Drive)



18-7634
TRIM SENDER
 Replaces: 984748
 Fits: OMC Cobra



18-2663
LOWER UNIT
SEAL KIT
 Replaces: 981797
 100-245 Stringer Unit (1968-77)

— CONTAINS —

Part #	Desc.	O.E. #	Qty.
18-0168	Grommet	908594	1
18-2012	Oil Seal	310599	4
18-2020	Oil Seal	310649	1
18-2058	Oil Seal	313353	2
18-2851	Swivel Bearing To Lower Gear Case Gsk.	313368	1
18-4248	Washer	311598	2
18-7120	O-Ring	307853, 322598	4
18-7129	O-Ring	314491	1
18-7135	O-Ring	310584	1
18-7167	O-Ring	310414	1

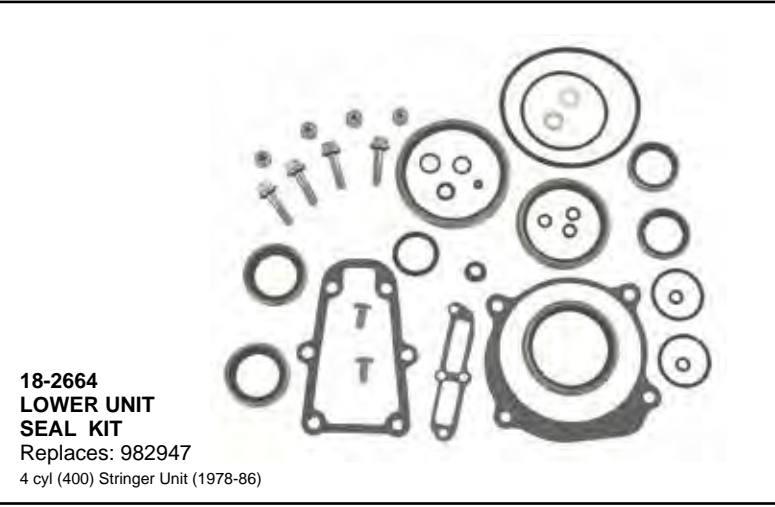

18-2664
LOWER UNIT
SEAL KIT
 Replaces: 982947
 4 cyl (400) Stringer Unit (1978-86)

— CONTAINS —

Part #	Desc.	O.E. #	Qty.
18-0110	Shift Housing Gasket	324670	1
18-3133	Housing Screw	908158	2
18-0188	Washer	909748	1
18-2020	Oil Seal	310649	1
18-2058	Oil Seal	313353	2
18-2060	Oil Seal	321467	2
18-3722	Locknut	121731	4
18-4248	Washer	311598	2
18-7101	O-Ring	305739	1
18-7102	O-Ring	307450	1
18-7120	O-Ring	307853, 322598	1
18-7127	O-Ring	313446	1
18-7130	O-Ring	314728	1
18-7178	O-Ring	320140	1
18-7404	O-Ring	909747	1
18-7475	Quad Ring	332583	4
18-7168	O-Ring	202893	1
18-7409	O-Ring	911871	2
18-2001	Oil Seal	330137	2
18-7479	O-Ring	—	1
18-3153	S.S. Bolt	908158	2

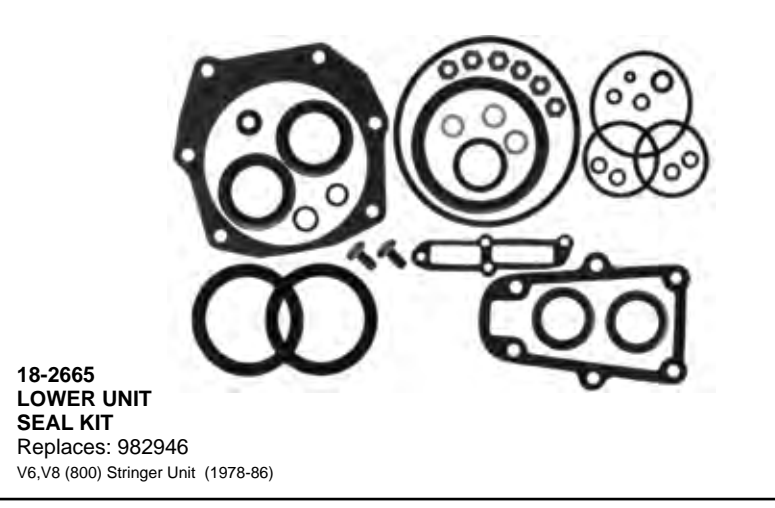

18-2665
LOWER UNIT
SEAL KIT
 Replaces: 982946
 V6,V8 (800) Stringer Unit (1978-86)

— CONTAINS —

Part #	Desc.	O.E. #	Qty.
18-0110	Shift Housing Gasket	324670	1
18-3133	Housing Screw	908158	2
18-0188	Washer	909748	1
18-2002	Oil Seal	320862	2
18-2020	Oil Seal	310649	1
18-2058	Oil Seal	313353	2
18-2060	Oil Seal	321467	2
18-2911	Swivel Bearing Housing Gasket	910236	1
18-3722	Locknut	121731	6
18-4248	Washer	311598	2
18-7101	O-Ring	305739	1
18-7102	O-Ring	307450	1
18-7120	O-Ring	307853, 322598	1
18-7130	O-Ring	314728	1
18-7142	O-Ring	322119	1
18-7178	O-Ring	320140	1
18-7403	O-Ring	909316	2
18-7404	O-Ring	909747	1
18-7475	Quad Ring	332583	4
18-7168	O-Ring	202893	1
18-7479	O-Ring	—	1
18-3153	S.S. Bolt	908158	2



18-2666
UPPER UNIT SEAL KIT
 Replaces: 981799
 100-245 Stringer Unit (1968-72)

— CONTAINS —

Part #	Desc.	O.E. #	Qty.
18-0939	Upper Gearcase Gasket	315189	1
18-2073	Oil Seal	981268	4
18-3111	Rubber Seal	907774	1
18-4248	Washer	311598	2
18-7103	O-Ring	308624	4
18-7107	O-Ring	313175	1
18-7121	O-Ring	308621	1
18-7134	O-Ring	303059	1
18-7146	O-Ring	554545	1
18-7173	O-Ring	910582	1
18-7198	O-Ring	308626	2
18-7158	O-Ring	310585, 310967	1
18-7172	O-Ring	553126	1

— CONTAINS —

Part #	Desc.	O.E. #	Qty.
18-0939	Upper Gearcase Gasket	315189	1
18-2072	Oil Seal	981196	2
18-2073	Oil Seal	981268	2
18-3111	Rubber Seal	907774	1
18-3725	Locknut	908064	1
18-4248	Washer	311598	2
18-4251	Plug	908062	1
18-7107	O-Ring	313175	1
18-7114	O-Ring	302540	1
18-7121	O-Ring	308621	1
18-7129	O-Ring	314491	1
18-7477	Quad Ring	909048	1
18-7168	O-Ring	202893	1
18-7172	O-Ring	553126	1
18-7173	O-Ring	910582, 310327	1



18-2667
UPPER UNIT SEAL KIT
 Replaces: 982949
 All Stringer Unit (1973-86)

— CONTAINS —

Part #	Desc.	O.E. #	Qty.
18-0917	Tilt Motor Gasket	311508	1
18-0923	Seal Gasket	313244	2
18-0939	Upper Gearcase Gasket	315189	1
18-0949	Trunion Cap Gasket	316499	2
18-2004	Oil Seal	—	1
18-2016	Oil Seal	313992	2
18-2066	Oil Seal	911019	1
18-2071	Oil Seal	981195	2
18-3725	Locknut	908064	1
18-4248	Washer	311598	1
18-4251	Plug	908062	1
18-7114	O-Ring	302540	1
18-7162	O-Ring	302337	1
18-7400	O-Ring	908194	1
18-7401	O-Ring	908383	1
18-7198	O-Ring	308626	2
18-2863	Tilt Clutch Cover Gasket	308799	1

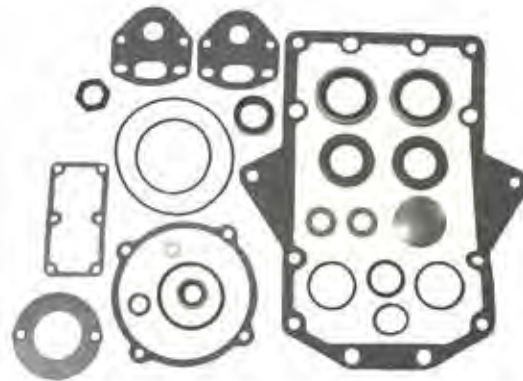

18-2669
INTERMEDIATE HOUSING SEAL KIT
 Replaces: 981801
 100-245 Stringer Unit (1973-77)

— CONTAINS —

Part #	Desc.	O.E. #	Qty.
18-2004	Oil Seal	—	1
18-2016	Oil Seal	313992	2
18-2060	Oil Seal	321467	2
18-2071	Oil Seal	981195	2
18-2863	Tilt Clutch Cover Gasket	308799	1
18-3725	Locknut	908064	1
18-4248	Washer	311598	3
18-4251	Plug	908062	1
18-7114	O-Ring	302540	1
18-7162	O-Ring	302337	1
18-7400	O-Ring	908194	1
18-7401	O-Ring	908383	1
18-7168	O-Ring	202893	3
18-7198	O-Ring	308626	2
18-0917	Tilt Motor Gasket	311508	1
18-0923	Seal	313244	2
18-0939	Upper Gearcase Dipstick Gasket	315189	1
18-0947	Pivot Cap Cover Gasket	909529	2
18-0913	Tilt Motor Gasket	909902	1

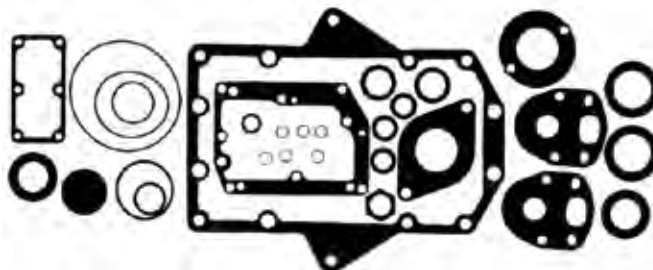

18-2670
INTERMEDIATE HOUSING SEAL KIT
 Replaces: 982948
 All Stringer Unit (1978-86)

— CONTAINS —

Part #	Desc.	O.E. #	Qty.
18-0880	Shift Cover Gasket	911878	1
18-0166	Grommet	911705	2
18-0190	Wiper	912157	1
18-4248	Washer	311598	2
18-7127	O-Ring	313446	1
18-7130	O-Ring	314728	1
18-7137	O-Ring	318372	1
18-7138	O-Ring	318717	3
18-7145	O-Ring	333572	2
18-7475	Quad Ring	332584	5
18-2001	Oil Seal	330137	2



18-2671
LOWER UNIT SEAL KIT
 Replaces: 985612
 All 4 cyl. Cobra (1986-89)



18-2672
LOWER UNIT SEAL KIT
 Replaces: 984458, 985613, 439967
 All V6/V8 Cobra (1986-1991)

— CONTAINS —

Part #	Desc.	O.E. #	Qty.
18-0880	Shift Cover Gasket	911878	1
18-0166	Grommet	911705	2
18-0190	Wiper	912157	1
18-2002	Oil Seal	320862	2
18-4248	Washer	311598	2
18-7130	O-Ring	314728	1
18-7137	O-Ring	318372	1
18-7138	O-Ring	318717	3
18-7142	O-Ring	322119	1
18-7145	O-Ring	333572	2
18-7475	Quad Ring	332584	5
18-0440	Water Passage Gasket	915719	1



18-2673
UPPER UNIT SEAL KIT
 Replaces: 984459, 986364, 987603
 All Cobra (1986-89)

— CONTAINS —

Part #	Desc.	O.E. #	Qty.
18-0911	Water Pump Base Gasket	911698	1
18-0884	Water Cover Gasket	911733	1
18-0166	Grommet	911705	2
18-2067	Oil Seal	911685	1
18-2068	Oil Seal	911701, 916058, 915000	1
18-2541	Rubber Seal	911704	1
18-2916	Water Pump Housing Gasket	911702	1
18-2918	Outdrive Gasket	915840	1
18-2996	Seal	911823	1
18-7107	O-Ring	313175	1
18-7116	O-Ring	303067	1
18-7138	O-Ring	318717	2
18-7153	O-Ring	—	2
18-7169	O-Ring	911686	1
18-7403	O-Ring	909316	1
18-7407	O-Ring	911700	1



18-2674
TRANSOM MOUNT SEAL KIT
 Replaces: 985518, 986423
 All Cobra (1986-89)

— CONTAINS —

Part #	Desc.	O.E. #	Qty.
18-2070	Oil Seal	911795	1
18-2138	Bearing	911787	3
18-2139	Bearing	911794	1
18-2533	Foam Seal	911797	1
18-2918	Outdrive Gasket	915840, 911836	1
18-2996	Seal	911823	1
18-4250	Washer	911820	2
18-7141	O-Ring	321117	12
18-7143	O-Ring	322501	1
18-7162	O-Ring	302337	1
18-7165	O-Ring	304174	1
18-7406	O-Ring	911311	3
18-7408	O-Ring	911718	2
18-7409	O-Ring	911871	1
18-7168	O-Ring	202893	1



18-2783
LOWER UNIT SEAL KIT
 Replaces: 986629
 King Cobra Lower Unit - 1990



18-2791
GEARCASE SEAL KIT
 Replaces: 987251, 3850597
 Fits: 3.0L, 4.3L, 5.0L (1994), 3.2L (1992-93),
 5.7L (1992-94), 7.4L (1992-95), 8.2L (1992-93)

SEAL KIT APPLICATION

Model	Year	Lower Gearcase Seal Kit	Upper Gearcase Seal Kit	Intermediate Housing Seal Kit	Transom Mount Seal Kit	Model	Year	Lower Gearcase Seal Kit	Upper Gearcase Seal Kit	Intermediate Housing Seal Kit	Transom Mount Seal Kit
2.3	1987-90	18-2671	18-2673	N/A	18-2674	165	1972	18-2663	18-2666	18-2668	N/A
2.5 ①	1982-86	18-2664	18-2667	18-2670	N/A	165	1973-76	18-2663	18-2667	18-2669	N/A
2.5 ②	1986	18-2671	18-2673	N/A	18-2674	170	1974	18-2663	18-2667	18-2669	N/A
3 ①	1982-86	18-2664	18-2667	18-2670	N/A	175	1975-77	18-2663	18-2667	18-2669	N/A
3 ②	1986-91	18-2671	18-2667	18-2670	N/A	185	1968	18-2663	18-2666	18-2668	N/A
4.3 ①	1985-86	18-2665	18-2667	18-2670	N/A	185	1978-80	18-2665	18-2667	18-2670	N/A
4.3 ②	1986-91	18-2672	18-2673	N/A	18-2674	190	1974-77	18-2663	18-2667	18-2669	N/A
3.8	1981-86	18-2665	18-2667	18-2670	N/A	200	1968	18-2663	18-2666	18-2668	N/A
5 ①	1982-86	18-2665	18-2667	18-2670	N/A	200	1979-81	18-2665	18-2667	18-2670	N/A
5 ②	1986-91	18-2672	18-2673	N/A	18-2674	210	1968-70	18-2663	18-2666	18-2668	N/A
5.7 ①	1982-86	18-2665	18-2667	18-2670	N/A	215	1971	18-2663	18-2666	18-2668	N/A
5.7 ②	1986-89	18-2672	18-2673	N/A	18-2674	225	1972	18-2663	18-2666	18-2668	N/A
5.7 ③	1990-91	18-2672	18-2673	N/A	18-2674	225	1973-76	18-2663	18-2667	18-2669	N/A
5.8	1989-90	18-2672	18-2673	N/A	18-2674	225	1978	18-2665	18-2667	18-2670	N/A
7.5	1987	—	18-2673	N/A	18-2674	230	1979-81	18-2665	18-2667	18-2670	N/A
80	1969	18-2663	18-2666	18-2668	N/A	235	1971	18-2663	18-2666	18-2668	N/A
90	1970	18-2663	18-2666	18-2668	N/A	235	1975-77	18-2663	18-2667	18-2669	N/A
100	1972	18-2663	18-2666	18-2668	N/A	240	1978	18-2665	18-2667	18-2670	N/A
100	1973	18-2663	18-2667	18-2669	N/A	245	1972	18-2663	18-2666	18-2668	N/A
120	1968-72	18-2663	18-2666	18-2668	N/A	245	1973-75	18-2663	18-2667	18-2669	N/A
120	1973-77	18-2663	18-2667	18-2669	N/A	250	1979	18-2665	18-2667	18-2670	N/A
120	1978-81	18-2664	18-2667	18-2670	N/A	260	1979-81	18-2665	18-2667	18-2670	N/A
140	1973-77	18-2663	18-2667	18-2669	N/A	262	1989	18-2672	18-2673	N/A	18-2674
140	1978-81	18-2664	18-2667	18-2670	N/A	350	1988-89	18-2672	18-2673	N/A	18-2674
155	1968-72	18-2663	18-2666	18-2668	N/A	460	1988-89	—	18-2673	N/A	18-2674

① Except Cobra ② Cobra ③ Except L.E. N/A Not Applicable

OIL SEALS



Part #	O.E. #	Shaft Size	Dimensions (in)		Part #	O.E. #	Shaft Size	Dimensions (in)	
			O.D.	Width				O.D.	Width
18-0542	321831	0.750	1.253	0.186	18-2034	324639	0.437	0.937	0.188
18-0543	321895	1.540	1.926	0.243	18-2035	327031	0.425	0.875	0.313
18-0559	332585	0.285	0.357	0.940	18-2058	313353	1.938	2.438	0.250
18-2000	309989	1.375	2.000	0.313	18-2059	321466	0.750	1.126	0.200
18-2001	330137	1.125	1.624	0.250	18-2060	321467	1.000	1.375	0.250
18-2002	320862	1.188	1.692	0.250	18-2061	329922	0.822	1.375	0.195
18-2005	313284	0.625	1.128	0.250	18-2062	329923	0.875	1.375	0.207
18-2012	310599	1.000	1.499	0.250	18-2063	330327	0.625	1.124	0.188
18-2016	313992	1.187	1.875	0.250	18-2064	332205	0.730	1.130	0.194
18-2018	305987	1.000	1.375	0.250	18-2065	332261	0.625	1.375	0.195
18-2020	310649	2.500	3.000	0.250	18-2066	911019	1.000	1.375	0.435
18-2021	302564	0.750	1.375	0.250	18-2067	911685	2.000	2.509	0.315
18-2022	303345	0.554	1.000	0.375	18-2068	911701	0.500	0.905	0.250
18-2023	313282	0.554	1.062	0.312	18-2068	915702	0.500	0.905	0.250
18-2024	314167	0.425	0.937	0.312	18-2068	916058	0.500	0.905	0.250
18-2025	318972	0.500	0.875	0.250	18-2068	3853655	0.500	0.905	0.200
18-2026	321453	0.875	1.250	0.188	18-2071	981195	1.500	2.125	0.250
18-2027	321459	0.625	1.125	0.250	18-2072	981196	1.750	2.502	0.250
18-2028	321480	0.500	1.250	0.188	18-2073	981268	1.625	2.502	0.250
18-2029	321481	0.687	1.250	0.250	18-2074	322575	1.625	2.125	0.250
18-2030	321786	0.625	1.125	0.188	18-2074	339620	1.625	2.125	0.250
18-2031	321787	0.625	1.125	0.312	18-2075	332942	1.562	2.062	0.300
18-2032	321788	0.500	1.000	0.188	18-8349	911795,	1.375	2.186	0.500
18-2033	321928	0.625	1.375	0.250		3852548			

UPPER GEARCASE (Cobra)				
ENGINE	YEAR	OIL SEAL	DESC.	QTY
262 - 460	1988-89	18-2067	BC	1
262 - 460	1988-90	18-2068	WPS	1
2.3 - 7.5	1986-90	18-2068	WPS	1
2.3 - 7.5	① 1986-90	18-2067	BC	1

① 5.7 '90 574 AMPWS, ARPWS
BC Bearing Carrier Seal
WPS Water Pump Seal

LOWER GEARCASE (Stringer)				
ENGINE	YEAR	OIL SEAL	DESC.	QTY
80/90	1968-71	18-2066	BR,L	2
80/90	1968-71	18-2066	PS	2
88/90	1964-68	18-2012	BR	1
80 - 260	1968-81	18-2020	BR,U	1
80 - 260	1968-81	18-2058	BR,M	2
110 - 200	① 1964-67	18-2012	BR	2
110 - 245	① 1964-77	18-2012	PS	2
110/120	② 1964-67	18-2012	BR	1
120 - 245	1968-77	18-2012	BR,L	2
120 - 260	1978-81	18-2060	BR,L	2
120/140	1978-81	18-2001	PS	2
155	③ 1967	18-2058	BR,M	2
155	③ 1967	18-2020	BR,U	1
185 - 260	1978-81	18-2002	PS	2
210 - 260	④ 1972-75	18-2066	IH	1
230/260	④ 1976	18-2060	IH	1
305/350/454	④ 1977-78	18-2060	IH	1
2.5/3.0	1982-86	18-2001	PS	2
2.5 - 5.7	1981-86	18-2020	BR,U	1
2.5 - 5.7	1981-86	18-2058	BR,M	2
2.5 - 5.7	1981-86	18-2060	BR,L	2
3.8 - 5.7	1981-86	18-2002	PS	2

① 110, 120 HP '64-67 Hvy. Duty Dr.
 ② Standard Drive
 ③ HU, HUE 16 C Models
 ④ Inboard
BR Driveshaft Bearing Retainer Seal
BR,U Driveshaft Bearing Retainer Upper Seal
BR,M Driveshaft Bearing Retainer Middle Seal
BR,L Driveshaft Bearing Retainer Lower Seal
IH Impeller Housing Seal
PS Prop Shaft Seal

UPPER GEARCASE (Stringer)				
ENGINE	YEAR	OIL SEAL	DESC.	QTY
80 - 245	1968-72	18-2073	BGS	1
80 - 260	1969-81	18-2073	IH	2
88 - 200	1964-66	18-2000	BGS	1
90	③ 1967	18-2000	BGS	1
90	④ 1967	18-2073	BGS	1
100 - 245	1972-73	18-2073	BGS	1
100 - 260	1973-81	18-2072	BGS	2
120	① 1967	18-2073	BGS	1
120	② 1967	18-2000	BGS	1
120	① 1967	18-2073	IH	2
120 - 210	1968	18-2073	IH	2
155	1967	18-2073	IH	2
155	⑤ 1967	18-2000	BGS	1
155	1967	18-2073	BGS	1
185	1967	18-2000	BGS	1
200	⑥ 1967	18-2000	BGS	1
200	⑦ 1967	18-2073	IH	2
200	⑦ 1967	18-2073	BGS	1
2.5 - 5.7	1981-86	18-2072	BGS	2
2.5 - 5.7	1981-86	18-2073	IH	2

① CU, CUE 16C Models
 ② CU15S Models
 ③ DU, DUE 14D Models
 ④ DU, DUE 15S Models
 ⑤ HU, HUE 15S Models
 ⑥ TU, TUE 15S Models
 ⑦ TU, TUE 16C Models
BGS Ball Gear Shaft Seal
IH Impeller Housing Seal

LOWER GEARCASE (Cobra)				
ENGINE	YEAR	OIL SEAL	DESC.	QTY
262 - 460	1988-89	18-2002	PS	2
2.3	1990	18-2001	PS	2
2.3 - 3.0	1986-89	18-2001	PS	2
3	1990	18-2002	PS	2
4.3 - 7.5	1986-90	18-2002	PS	2

PS Prop Shaft Seal

INTERMEDIATE HOUSING (Stringer)				
ENGINE	YEAR	OIL SEAL	DESC.	QTY
80 - 235	1964-71	18-2000	BG,O	1
80 - 245	1964-72	18-2001	BG,I	1
80 - 260	② 1964-80	18-2066	CL	1
100 - 245	1972	18-2000	BG,O	2
100 - 260	1973-79	18-2016	BG,I	1
100 - 260	1973-81	18-2071	BG,O	2
120 - 260	1980-81	18-2016	BG,I	2
120 - 260	① 1980-81	18-2060	CL	2
2.5 - 5.7	1981-86	18-2060	CL	2
2.5 - 5.7	1981-86	18-2016	BG,I	2
2.5 - 5.7	1981-86	18-2071	BG,O	2

CL Clutch
 ① 120, 140 '80C Models/185—260 '80 K&U Models
 ② C Models in '80
BG,I Driveshaft Ball Gear Inner Seal
BG,O Driveshaft Ball Gear Outer Seal



O-RINGS

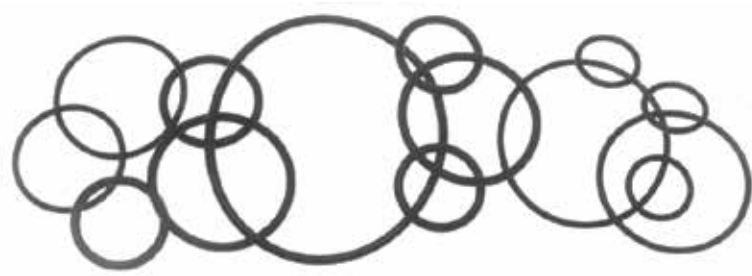

Part #	O.E. #	Dimensions (in)		Part #	O.E. #	Dimensions (in)	
		I.D.	Width			I.D.	Width
18-7100	② ⑤ 301877	.245	.155	18-7150	③ ⑤ 331380	.225	.115
18-7101	② ⑤ 305739	.250	.065	18-7150	③ ⑤ 334913	.225	.115
18-7102	② ⑤ 307450	.430	.065	18-7152	② ⑤ 307082	2.625	.135
18-7103	② ⑤ 308624	.920	.100	18-7153	① 3852565, 911851	.0860	.100
18-7104	② ⑤ 308627	2.210	.135	18-7155	② ⑤ 305270	1.620	.135
18-7105	② ⑤ 311338	.750	.065	18-7156	② ⑤ 309731	1.185	.100
18-7107	② ⑤ 313175	4.750	.135	18-7158	② ⑤ 310585	.740	.100
18-7108	② ⑤ 313893	2.550	.100	18-7162	② ⑤ 302337	2.025	.135
18-7108	② ⑤ 338518	2.550	.100	18-7164	② ⑤ 302537	1.375	.100
18-7109	② ⑤ 317178	.214	.048	18-7165	② ⑤ 304174	.500	.065
18-7111	① 301824	.197	.113	18-7167	② ⑤ 310414	3.625	.135
18-7112	① 302493	1.170	.135	18-7168	② ⑤ 202893	.370	.065
18-7114	② ⑤ 302540	1.000	.135	18-7169	② ⑤ 911686	3.500	.135
18-7115	① 302588	1.735	.135	18-7170	① 307239	1.365	.135
18-7116	① 303067	.360	.100	18-7172	② ⑤ 553126	3.250	.135
18-7117	① 303360	1.060	.135	18-7173	② ⑤ 310327	1.875	.135
18-7118	② ⑤ 305242	.300	.135	18-7174	② ⑤ 326649	.620	.100
18-7120	① 307853	.215	.065	18-7178	② ⑤ 320140	.920	.135
18-7120	① 332598	.215	.065	18-7180	② ⑤ 303347	.445	.090
18-7121	① 308621	3.100	.135	18-7180	② ⑤ 303347	.445	.090
18-7123	① 308876	2.235	.100	18-7198	② ⑤ 308626	1.430	.100
18-7126	① 313340	1.690	.100	18-7400	② ⑤ 908194	4.000	.100
18-7127	① 313446	3.315	.135	18-7401	② ⑤ 908383	2.485	.100
18-7128	① 313754	1.835	.100	18-7403	② ⑤ 909316	1.500	.100
18-7129	② ⑤ 314491	.970	.065	18-7404	② ⑤ 909747	.300	.100
18-7130	① 314728	2.125	.100	18-7406	② ⑤ 911311	0.250	.065
18-7133	② ⑤ 305123	3.780	.135	18-7407	② ⑤ 911700	4.125	.135
18-7134	② ⑤ 303059	.500	.100	18-7407	② ⑤ 3852531	4.125	.135
18-7135	① 310584	.750	.135	18-7408	② ⑤ 911718	1.060	.100
18-7137	② ⑤ 318372	0.320	.155	18-7409	② ⑤ 911871	1.175	.100
18-7138	② ⑤ 318717	1.500	.210	18-7413	② ⑤ 303191	.301	.070
18-7139	② ⑤ 319085	1.080	.210	18-7416	② ⑤ 329380	.612	.103
18-7140	② ⑤ 320303	2.750	.135	18-7417	② ⑤ 329381	.362	.103
18-7141	② ⑤ 321117	.180	.065	18-7418	② ⑤ 326741	4.484	.139
18-7142	② ⑤ 322119	3.940	.135	18-7440-1	④ 301967	.799	.103
18-7143	② ⑤ 322501, 331188	1.310	.100	18-7457	① 319662	1.799	.103
18-7144	② ⑤ 326849	4.250	.135	18-7461	① 308458	1.612	.103
18-7145	② ⑤ 333572	.250	.100	18-7475	② ⑤ 332584	.250	.065
18-7146	② ⑤ 554545	1.120	.100	18-7477	② ⑤ 909048	.480	.100
18-7150	③ ⑤ 303598	.225	.115	18-7510	① 321163	2.750	.070

① Pkg. of 1 ② Pkg. of 5 ③ Pkg. of 10 ④ Indicates Quad Rings rather than O-Rings

TRANSOM MOUNT (Cobra)					TRANSOM MOUNT (Cobra) (Cont.)				
ENGINE	YEAR	O-RING	DESC.	QTY.	ENGINE	YEAR	O-RING	DESC.	QTY.
262 - 460	1988-89	18-7165	SCS	1	2.3 - 7.5	① 1986-90	18-7165	SCS	1
262 - 460	1988-89	18-7408	NP	2	2.3 - 7.5	① 1986-90	18-7409	SC	1
262 - 460	1988-89	18-7409	SC	1	2.3 - 7.5	1986-90	18-7143	MB	1
262 - 460	1988-89	18-7406	PL	1					
262 - 460	1988-89	18-7168	BC	1					
262 - 460	1988-90	18-7162	UG	1					
262 - 460	1988-90	18-7143	MB	1					
2.3 - 7.5	① 1986-90	18-7168	BC	1					
2.3 - 7.5	1986-90	18-7162	UG	1					
2.3 - 7.5	① 1986-90	18-7406	PL	1					
2.3 - 7.5	① 1986-90	18-7408	NP	2					

① 5.7 '90 574 AMPWS, ARPWS
BC Bell Crank Seal
MB Manifold Block Seal
UG Upper Gimbal Seal
SCS Shift Cable Seal
PL Plug Seal
NP Nipple Seal
SC Sleeve and Connector Seal

⑤ This product is priced per piece. To order priced per package, please add -9 to the part number.

UPPER GEARCASE (Cobra)				
ENGINE	YEAR	O-RING	DESC.	QTY
262 - 460	1988-89	18-7403	A,S	1
262 - 460	1988-89	18-7107	GHC	1
262 - 460	1988-89	18-7407	A,L	1
262 - 460	1988-90	18-7169	BC	1
350 - 460	1990	18-7116	OFF	1
350 - 460	1990	18-7407	BC	1
350 - 460	1990	18-7406	WDP	1
370	1988	18-7407	AB	1
460	1990	18-7407	BC	1
2.3 - 5.8	1990	18-7116	OFF	1
2.3 - 7.5	① 1986-90	18-7107	GHC	1
2.3 - 7.5	① 1986-90	18-7407	A,L	1
2.3 - 7.5	1986-90	18-7169	BC	1
2.3 - 7.5	① 1986-90	18-7403	A,S	1
5.7	② 1990	18-7406	WDP	1
5.7	② 1990	18-7407	BC	1

- ① 5.7 '90 574 AMPWS, ARPWS
- ② 574 PEPWS
- GHC** Gear Hsg. Cover Seal
- OFF** Oil Fill Plug Seal
- BC** Bearing Carrier Seal
- A,S** Adaptor, Small Seal
- A,L** Adaptor, Large Seal
- WDP** Water Drain Plug Seal
- AB** Anchor Block Seal

LOWER GEARCASE (Cobra)				
ENGINE	YEAR	O-RING	DESC.	QTY
262/350	1988-89	18-7475	PBHS	4
262/350	1988-89	18-7142	PBH	1
262 - 460	1988-89	18-7130	DS B	1
262 - 460	1988-89	18-7475	BSS	1
262 - 460	1988-89	18-7138	DS BH	3
262 - 460	1988-89	18-7137	SR	1
350 - 460	1990	18-7145	PL	1
370	1988	18-7130	SL	2
370/460	1988-89	18-7145	D&F S	2
2.3	1987	18-7145	D&F S	2
2.3	1990	18-7127	PBH	1
2.3 - 3.0	1986-89	18-7127	PBH	1
2.3/3.0	1988-90	18-7145	D&F S	2
2.5 - 5.7	1986	18-7145	D&F S	2
2.3 - 5.8	① 1986-90	18-7475	PBHS	4
2.3 - 7.5	① 1986-90	18-7475	BSS	1
2.3 - 7.5	① 1986-90	18-7138	DS BH	3
2.3 - 7.5	① 1986-90	18-7137	SR	1
2.3 - 7.5	① 1986-90	18-7130	DS B	1
3.0 - 5.8	① 1990	18-7142	PBH	1
4.3 - 5.8	1989-89	18-7142	PBH	1
5.7	② 1990	18-7145	PLUG	1

- ① 5.7 '90 574 AMPWS, ARPWS
- ② 574 PEPWS
- BSS** Bearing Setscrew Seal
- DS BH** Driveshaft Bearing Hsg. Seal
- DS B** Driveshaft Bearing Seal
- D&F S** Drain & Fill Screw Seal
- PBH** Prop Bearing Hsg. Seal
- PBHS** Prop Bearing Hsg. Screw Seal
- PL** Plug Seal
- SR** Shift Rod Seal
- SL** Sleeve Seal

POWER TILT AND TRIM (Cobra)				
ENGINE	YEAR	O-RING	DESC.	QTY
262 - 460	1988-90	18-7141	OL	12
262 - 460	1988-90	18-7102	PL	1
350 - 460	1988	18-7174	VSH	1
350 - 460	1988	18-7168	VS	4
350 - 460	1988	18-7174	VA,L	2
350 - 460	1988	18-7165	VA,S	2
2.3 - 7.5	1986-88	18-7174	VSH	1
2.3 - 7.5	1986-88	18-7168	VS	4
2.3 - 7.5	1986-88	18-7174	VA,L	2
2.3 - 7.5	1986-88	18-7165	VA,S	2
2.3-7.5	1986-90	18-7102	PL	1
2.3-7.5	1986-90	18-7141	OL	12

- PL** Plug Seal
- VS** Valve Seat Assy. Seal
- VA,L** Valve Assy., Large Seal
- VA,S** Valve Assy., Small Seal
- VSH** Valve Seat Hsg. Seal
- OL** Oil Line Seal

OIL AND COOLING SYSTEM (Cobra)				
ENGINE	YEAR	O-RING	DESC.	QTY
262/454	1989-90	18-7135	AR	1
262 - 460	1988-90	18-7116	ODF	1
350/460	1988-90	18-7135	AR	1
370	1988	18-7162	THERM	1
2.3 - 5.8	1988-90	18-7116	ODF	1
4.3	① 1990	18-7135	AR	1
7.5	1987	18-7135	AR	1

- ① V-4 Only
- ODF** Oil Drain Fitting Seal
- AR** Adapter Retainer Seal
- THERM** Thermostat Seal

POWERHEAD (Stringer)				
ENGINE	YEAR	O-RING	DESC.	QTY
80/90	1969-71	18-7108	WP	1
88	1964	18-7133	CCH	3
88/90	1964-68	18-7120	CCHS	4
90	1965-68	18-7133	CCH	4
120/140	1977-80	18-7114	CP	1
120 - 235	1976	18-7114	CP	1

- WP** Water Pump Seal
- CCH** Crankcase Head Seal
- CCHS** Crankcase Head Screw Seal
- CP** Coupling Seal

INTERMEDIATE HOUSING (Stringer)				
ENGINE	YEAR	O-RING	DESC.	QTY
80	1968	18-7162	SL	1
80 - 90	1964-68	18-7174	WT	1
80 - 210	1964-70	18-7123	BGR	1
80 - 245	① 1964-72	18-7174	PS	1
80 - 260	1964-81	18-7198	COV	2
80 - 260	1964-81	18-7114	WR	1
80 - 260	1969-81	18-7162	SL	1
88	1964	18-7104	TH	1
88	1964	18-7174	TC	1

INTERMEDIATE HOUSING (Stringer) (Cont.)

ENGINE	YEAR	O-RING	DESC.	QTY
90 - 235	1970-71	18-7158	DS	1
90 - 235	② 1971	18-7123	BGR	1
100 - 260	1973-81	18-7401	BGR	1
100 - 260	1973-81	18-7400	TUC	1
120	③ 1967	18-7162	SL	1
120 - 210	1968	18-7162	SL	1
120/140	1981	18-7168	FS	3
155	④ 1967	18-7162	SL	1
2.5 - 5.7	1981-86	18-7400	TUC	1
2.5 - 5.7	1981-86	18-7198	COV	2
2.5 - 5.7	1981-86	18-7114	WR	1
2.5 - 5.7	1981-86	18-7401	BGR	1
2.5 - 5.7	1981-86	18-7162	SL	1
2.5 - 5.7	1982	18-7168	FS	3

- ① Rope or Pull-Pull Steering Models
- ② All 90/120, 155, 210 EX Models/235 XUFM20S prior to S/N 202880 and 235 XUFM20S prior to S/N 204600
- ③ CU, CUE 16C
- ④ 120, 155, 215, 20D Models/235 XUFR20S S/N 202880 & up and 235 XUFM20S S/N 204600 & up 235 20D all Models
- COV** Pivot Cap Cover Seal
- BGR** Ball Gear Retainer Seal
- DS** Driveshaft to Hsg. Seal
- TC** Driveshaft Tube Cover Seal
- TH** Driveshaft Tube to Hsg.
- FS** Fill Screw Seal
- PS** Pulley Shaft
- SL** Sleeve to Hsg. Seal
- TUC** Tilt Unit Cover Seal
- WT** Water Tube Seal
- WR** Worm Gear Retainer Seal

UPPER GEARCASE (Stringer)

ENGINE	YEAR	O-RING	DESC.	QTY
80 - 90	1968-71	18-7158	BG	1
80 - 90	1964-68	18-7174	IH	1
80 - 245	① 1964-72	18-7103	WG	1
80 - 245	① 1964-74	18-7134	G	1
80 - 260	1964-81	18-7172	IH	1
80 - 260	1964-81	18-7121	BGR	1
80 - 260	1968-80	18-7173	WW	1
80 - 260	② 1968-81	18-7107	WW	1
90	③ 1967	18-7107	WW	1
90 - 200	1964-67	18-7128	CAP	1
90 - 200	1965-67	18-7173	WW	2
90 - 245	④ 1967-72	18-7146	BG	1
100 - 245	1973-75	18-7114	WS	1
100 - 260	1973-81	18-7129	DS IH	1
110 - 120	⑤ 1964-67	18-7158	IH	1
110 - 120	⑥ 1964-67	18-7174	IH	1
120 - 200	⑦ 1967	18-7107	WW	1
120 - 235	1968-71	18-7158	IH	1
120 - 260	1975-81	18-7477	G	1
150 - 210	1964-67	18-7158	IH	1
2.5/3.0	1982	18-7168	OP	1
2.5 - 5.7	1981-86	18-7477	G	1
2.5 - 5.7	1981-86	18-7172	IH	1
2.5 - 5.7	1981-86	18-7107	WW	1
2.5 - 5.7	1981-86	18-7121	BGR	1
2.5 - 5.7	1981-86	18-7129	DS IH	1

UPPER GEARCASE (Stringer) (Cont.)

- ① Rope or Pull-Pull Steering Models
- ② 155 HP 1968 HU, HUE 16C
- ③ DU, DUE 15S
- ④ 90 HP '67 DU, DUE 15S/120 and 200 '67 16C Models
- ⑤ Heavy Duty Drive
- ⑥ Standard Gearcase
- ⑦ 16C Models
- BG** Ball Gear Seal
- BGR** Ball Gear Retainer Seal
- DS IH** Driveshaft Impeller Hsg. Seal
- IH** Impeller Hsg. Seal
- CAP** Gear Hsg. Cap Seal
- OP** Oil Plug Seal
- WR** Steering Worm Wheel Retainer Seal
- WS** Steering Worm Wheel Spacer Seal
- WG** Steering Worm Wheel Gear Seal
- WW** Steering Worm Wheel Seal
- G** Gear Seal

LOWER GEARCASE (Stringer)

ENGINE	YEAR	O-RING	DESC.	QTY
80 - 90	1964-69	18-7120	PBH S	4
80 - 90	1964-71	18-7152	PBH	1
80 - 90	1964-71	18-7115	BR	1
80 - 90	1964-71	18-7174	DS	1
88/90	1964-68	18-7173	DSB	2
90 - 245	1970-77	18-7120	PBH S	4
100 - 245	1968-72	18-7135	BR	1
100 - 245	1969-77	18-7167	PBH	1
110/120	② 1964-67	18-7167	PBH	1
110/120	① 1964-67	18-7174	DS	1
110/120	② 1964-67	18-7135	BR	1
110/120	① 1964-67	18-7152	PBH	1
110/120	① 1964-67	18-7173	DSB	2
110/120	① 1964-67	18-7115	BR	1
120	① 1964-67	18-7120	PBH S	4
120/140	1978-81	18-7127	PBH	1
120/140	1978	18-7156	SA,L	2
120 - 235	1977	18-7129	DS	1
120 - 240	1978	18-7178	SA,S	1
120 - 260	1978-81	18-7130	BR	1
120 - 260	1978-81	18-7102	PIN	1
120 - 260	1978-81	18-7109	PBH S	4
120 - 260	1978-81	18-7404	PIN	1
120 - 260	1979-81	18-7120	BSS	1
120 - 260	1981	18-7168	D&F S	1
150 - 200	1964-67	18-7135	BR	1
150 - 210	1964-68	18-7167	PBH	1
185 - 240	1978	18-7403	SA,L	2
185 - 260	1978-81	18-7142	PBH	1
2.5 - 5.7	1981-82	18-7168	D&F S	1
2.5 - 5.7	1981-83	18-7109	PBH S	4
2.5 - 5.7	1981-86	18-7130	BR	1
2.5 - 5.7	1981-86	18-7102	PIN	1
2.5 - 5.7	1981-86	18-7404	PIN	1
2.5 - 5.7	1981-86	18-7120	BSS	1
2.5 - 5.7	1981-86	18-7142	PBH	1
2.5/3.0	1982-86	18-7127	PBH	1
3.8	1981	18-7101	OSV	1

- ① Standard Drive
- ② Heavy Duty Drive
- OSV** Oil Stem Valve Seal
- PIN** Pinion Shaft Seal
- BR** Driveshaft Bearing Retainer Seal
- DS** Driveshaft Seal
- PBH** Prop Bearing Hsg. Seal
- DSB** Driveshaft Bushing Seal
- PBH S** Prop Bearing Hsg. Screw Seal
- D&F S** Drain & Fill Screw Seal
- SA,L** Shift Assy., Large Seal
- SA,S** Shift Assy., Small Seal
- BSS** Bearing Set Screw Seal